



AQUAMATIC[®] STAGER PILOT VALVES

IDEAL FOR CONTROL OF DIAPHRAGM VALVES



FEATURES/BENEFITS

Stagers are motor-driven rotary multiport pilot valves, which are used to control a set of diaphragm valves in a predefined sequence

Constructed of durable, noncorroding, self-lubricating material for long and trouble-free operation

Control pressure to the stager, either hydraulic or pneumatic, must be constant and equal to or greater than the line pressure in the system

Electrical stagers are available for use in 120 VAC, 220 VAC, 12 VAC and 24 VAC configurations

All stagers can be manually operated if power is not available

OPTIONS

Supplied with a maximum of two extra auxiliary cams and switches [SPDT] for electrical outputs in any position

Supplied in a NEMA-rated enclosure or without enclosure

TYPICAL APPLICATIONS

Condensate Polishers

Deionizers

Water Treatment Systems

OPERATING SPECIFICATIONS

Max Pressure	125 psi (8.6 bar)	
Max Temperature	150°F (65°C)	
Body Material	Model 48 & 51:	Brass
	Model 58:	PVC
Internal Gasket	Neoprene	
Stem Plate	PTFE	
Control Ports	Model 48:	6
	Model 51:	8
	Model 58:	16
Inlet Port Size NPT	Model 48 & 51:	1/8"
	Model 58:	1/4"
Drain Port Size NPT	Model 48 & 51:	1/8"
	Model 58:	1/4"
Control Port Size NPT	Model 48, 51, 58:	1/8"
Power Usage in Watts	Model 48 & 51:	4.0 max
	Model 58:	3.5 max

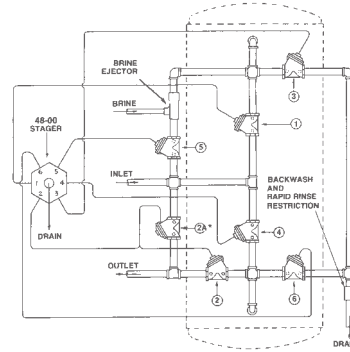

**Stager
(Model 48-00)**

*Valve 2A required for raw water bypass only.

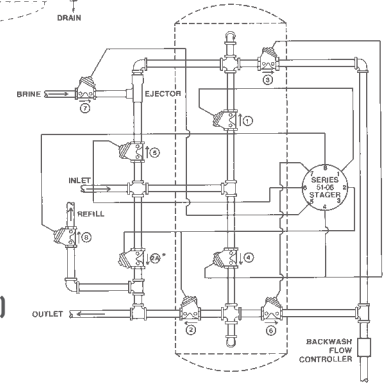

**Stager
(Model 51-06)**

STANDARD STAGER PROGRAMS

STAGER DESIGNATION	NUMBER OF POSITION	APPLICATION	SUGGESTED PIPING DWG
48-00	4	4 Position Softener	1078271
48-01	3	3 Position Filter	1078272
48-83	4	3 Tank Sequential Filter, Backwash Only	1078276
48-84	5	4 Tank Sequential Filter, Backwash Only	1078277
48-85	6	5 Tank Sequential Filter, Backwash Only	1078278
51-06	6	6 Position Softener, Timed Brine and Refill	1078279
51-07	5	5 Position Softener, Timed Brine	1078280
51-09	5	5 Position Softener, Timed Brine Refill	1078281
51-10	5	2 Tank Sequential Filter, Backwash and Rinse	1078282
51-86	7	6 Tank Sequential Filter, Backwash Only	1078286
51-87	8	7 Tank Sequential Filter, Backwash Only	1078287
58-00	9	2 Bed Deionization	1078290
58-02	9	2 Bed Deionization with De-Gasifier	1078291
58-03	7	3 Tank Sequential Filter, Backwash and Rinse	1078288
58-04	8	4 Tank Sequential Filter, Backwash and Rinse	1078289
58-10	10	Mixed Bed Deionization	1078292
58-TA	8	2 Tank Alternating Softeners	1078293
58-TB	10	2 Tank Alternating Softeners, with Timed Brine	1078294