

# DATA SHEET

## 15 FRAME PLUNGER PUMPS



**Brass**  
**1540E**

**Flushed**  
**1540EC**

**Stainless Steel**  
**1541**

**Stainless Steel Flushed**  
**1541C**



Model 1540E Shown  
(Rails and shaft protector sold separately)

SPECIFICATIONS	U.S. Measure	Metric Measure
Flow	18.0 gpm	68 lpm
Pressure Range	100 to 1200 psi	6.9 to 83 bar
Pump RPM*	1100 rpm	1100 rpm
Inlet Pressure Range	Flooded to 70 psi	Flooded to 4.8 bar
Max. Liquid Temperature	140° F	60° C
Above 130°F call Cat Pumps for inlet conditions and elastomer recommendations.		
Bore	1.181"	30 mm
Stroke	1.181"	30 mm
Crankcase Capacity	42 oz.	1.26 l
Inlet Ports (2)	1" NPT(F)	1" NPT(F)
Flush Ports (2) (1540EC, 1541C)	1/8" NPT(F)	1/8" NPT(F)
Discharge Ports (2)	3/4" NPT(F)	3/4" NPT(F)
Pulley Mounting	Either Side	Either Side
Shaft Diameter	1.181"	30 mm
Weight	42.6 lbs.	21 kg
Dimensions	14.57 x 12.99 x 6.42"	370 x 330 x 163 mm

\*Pump minimum is 100 RPM.

### FEATURES

- Triplex design offers high efficiency and low pulsation.
- Durable high pressure seals are lubricated and cooled by pumped liquid.
- Pre-set Lo-Pressure Seals provide secondary protection against external leaks and require no packing adjustment.
- Special high density, polished, concentric plungers provide a true wear surface and extended seal life.
- Wet-end easily serviced without entering crankcase.
- Standard NBR seals with alternative options for temperature and chemical compatibility.
- FPM – .0110

### ELECTRIC HORSEPOWER REQUIREMENTS

MODELS	FLOW		PRESSURE			PUMP RPM
			psi 800 bar 55	psi 1000 bar 69	psi 1200 bar 83	
	gpm	lpm				
<b>1540E</b>	18	68	9.9	12.3	14.8	1100
<b>1540EC</b>	18	68	9.9	12.3	14.8	1100
<b>1541</b>	18	68	9.9	12.3	14.8	1100
<b>1541C</b>	18	68	9.9	12.3	14.8	1100

$$\text{DETERMINING THE PUMP R.P.M.} \quad \frac{\text{Rated gpm}}{\text{Rated rpm}} = \frac{\text{"Desired" gpm}}{\text{"Desired" rpm}}$$

$$\text{DETERMINING THE REQUIRED H.P.} \quad \frac{\text{Hp (Electric Brake)}}{1460} = \frac{\text{gpm} \times \text{psi}}{1460}$$

$$\text{DETERMINING MOTOR PULLEY SIZE} \quad \frac{\text{Motor Pulley O.D.}}{\text{Pump rpm}} = \frac{\text{Pump Pulley O.D.}}{\text{Motor rpm}}$$

See complete Drive Packages [Includes: pulleys, belts, hubs, key] Tech Bulletin 003.  
Refer to pump **Service Manual** for repair procedure and additional technical information.

# PARTS LIST

ITEM	PART NUMBER		DESCRIPTION	QTY		
	1540E 1540EC	MATL			1541 1541C	MATL
2	990036	STL	990036	STL	Key (M8x7x40) Use w/30059 and 990012 "H" Hubs	1
—	30067	STL	30067	STL	Key (M8x7.5x25) Use w/30059 "H" Hub	1
5	92538	S	92538	S	Screw, HHC Sems (M6x16)	8
8	<b>49535</b>	ALE	<b>43496</b>	AL	Cover, Bearing (See Tech Bulletin 118)	2
9	815281	FBR	815281	FBR	Shim, Split 2-Pc	3
10	11340	NBR	11340	NBR	O-Ring, Bearing Cover - 70D	2
11	43495	NBR	43495	NBR	Seal, Oil, Crankshaft - 70D	2
12	814800	S	814800	S	Shim, Split, 2-Pc	2
15	39060	STL	39060	STL	Bearing, Roller	2
20	48600	TNM	48600	TNM	Rod, Connecting Assembly	3
25	43494	FCM	43494	FCM	Crankshaft, Dual-End (M30)	1
31	828710	PE	828710	PE	Protector, Oil Cap w/Foam Gasket	1
32	43211	ABS	43211	ABS	Cap, Oil Filler	1
33	14177	NBR	14177	NBR	O-Ring, Filler Cap - 70D	1
37	92241	—	92241	—	Gauge, Oil, Bubble w/Gasket - 80D	1
38	44428	NBR	44428	NBR	Gasket, Flat, Oil Gauge - 80D	1
40	92542	S	92542	S	Screw, HHC Sems (M6x20)	4
48	25625	STCP	25625	STCP	Plug, Drain (1/4"x19BSP)	1
49	23170	NBR	23170	NBR	O-Ring, Drain Plug - 70D	1
50	<b>49276</b>	ALE	<b>43491</b>	AL	Cover, Rear (See Tech Bulletin 118)	1
51	44834	NBR	44834	NBR	O-Ring, Rear Cover - 70D	1
53	<b>49273</b>	ALE	<b>48925</b>	AL	Crankcase (Includes Guidepin) (See Tech Bulletin 118)	1
64	43507	CM	43507	CM	Pin, Crosshead	3
65	<b>48933</b>	SHS	<b>49611</b>	SS	Rod, Plunger (Center)	1
66	<b>48931</b>	SHS	<b>49609</b>	SS	Rod, Plunger (Outside)	2
69	126596	STCP R	126596	STCP R	Washer, Oil Seal	3
70	43500	NBR	43500	NBR	Seal, Oil Crankcase - 80D	3
88	48937	S	48937	S	Washer, Flat	3
90	48938	CC	48938	CC	Plunger, Ceramic (M30x65)	3
98	46730	NBR	46730	NBR	Washer, Seal - 90D	3
	48394	FPM	48394	FPM	Washer, Seal - 90D	3
99	† 48201	SS	48201	SS	Retainer, Plunger	3
100	48936	PVDF	48936	PVDF	Retainer, Seal	3
106	<b>49067</b>	NBR	—	—	Seal, LPS w/S-Spg	3
	—	—	<b>49616</b>	NBR	Seal, LPS w/SS-Spg	3
	<b>702939</b>	ST4	—	—	Seal, w/NiH-Spg	3
110	<b>48940</b>	FBB	<b>49614</b>	SS	Manifold, Inlet	1
	<b>49853</b>	FBB	<b>134147</b>	SS	Manifold, Inlet Flushed [1/8" NPT(F) Port]	1
112	123903	NBR	123903	NBR	O-Ring, Inlet Manifold - 90D	3
	76903	FPM	76903	FPM	O-Ring, Inlet Manifold - 80D	3
117	49044	S	49044	S	Screw, HSH (M10x25)	4
125	<b>48944</b>	SNG	—	—	Seal, HPS w/S	3
	<b>49619</b>	STG	<b>49619</b>	STG	Seal, Assy 2 piece w/SS-Support	3
155	123903	NBR	123903	NBR	O-Ring, Spacer - 90D	6
	76903	FPM	76903	FPM	O-Ring, Inlet Manifold - 80D	6
157	<b>48946</b>	BB	<b>49621</b>	SS	Spacer, HPS	3
163	26143	NBR	26143	NBR	O-Ring, Seat - 80D	6
	14331	FPM	14331	FPM	O-Ring, Seat - 70D	6
164	<b>48951</b>	S	<b>49626</b>	SS	Seat	6
166	48686	SS	48686	SS	Valve	6
167	48687	SS	48687	SS	Spring	6
168	48994	PVDF	48994	PVDF	Retainer, Spring	6
170	<b>123764</b>	S	<b>49627</b>	SS	Washer, Spring Retainer	6
172	17629	NBR	17629	NBR	O-Ring, Valve Plug - 80D	3
	14183	FPM	14183	FPM	O-Ring, Valve Plug	3
174	<b>48952</b>	FBB	<b>49628</b>	SS	Plug, Valve	3
185	<b>48948</b>	FBB	<b>49623</b>	SS	Manifold, Discharge	1
188	87952	S	87952	S	Screw, HSH (M10x55)	10
250	<b>30764</b>	NYR	—	—	Protector, Shaft w/2 Screws PN 125824	1
	—	—	<b>30764S</b>	NY	Protector, Shaft w/2 Screws PN 92538	1
260	30613	STZP	30613	STZP	Mounting, Angle Rail	1
269	30206	F	30206	F	Pulley (10") 2 groove [See Tech Bulletin 003]	1
270	30059	STL	30059	STL	Hub, "H", M30 (Keyway M8) [See Tech Bulletin 003]	1
	990012	STL	990012	STL	Hub, "B", M30 (Keyway M8) [See Tech Bulletin 003]	1
283	34334	—	34334	—	Kit, Oil Drain (3/8" x 24")	1
299	<b>816863</b>	FBB	<b>818443</b>	SS	Head, Complete w/NBR Seals and O-Rings (Models 1540E, 1541 only)	1

# EXPLODED VIEW

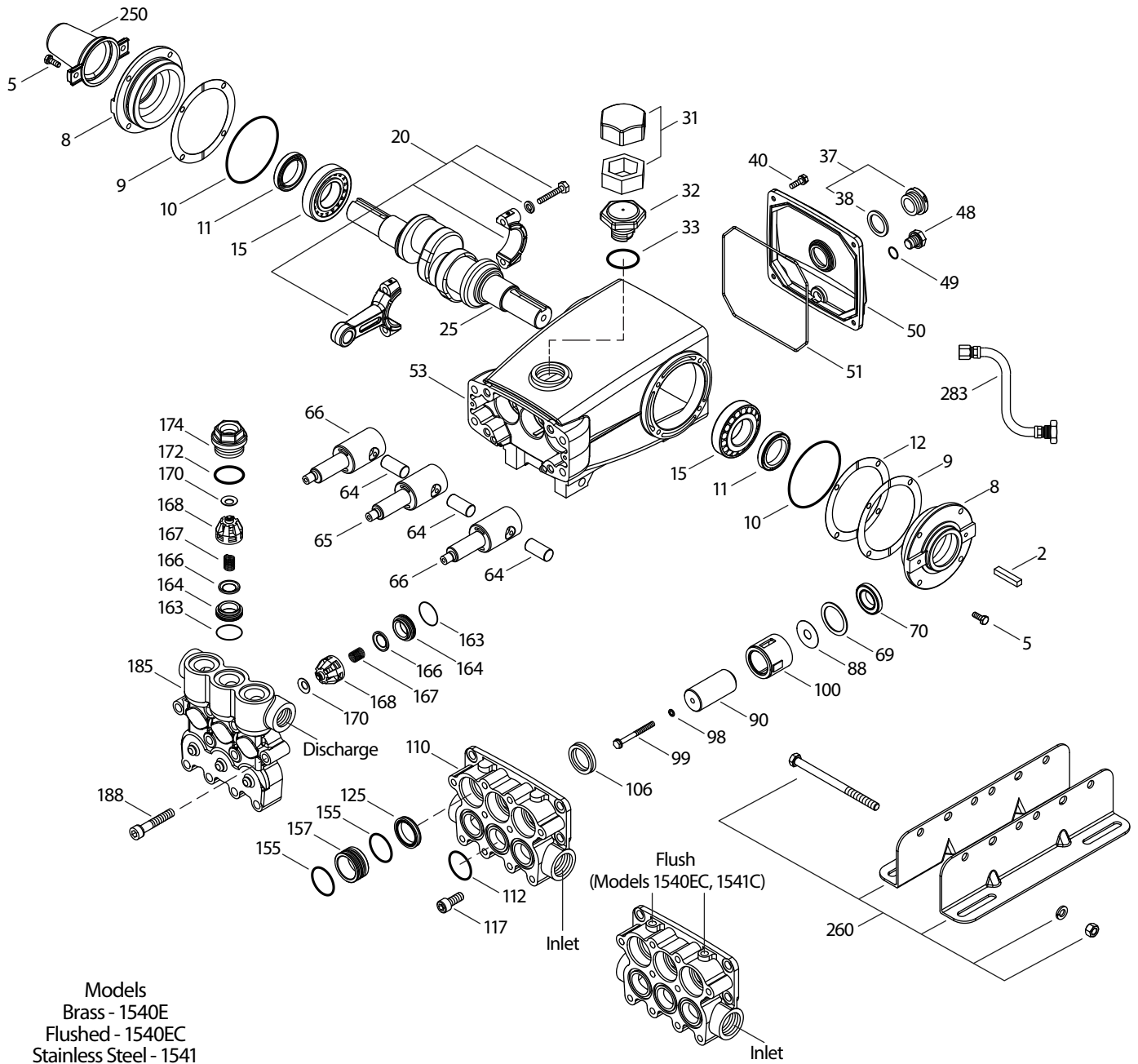

Models  
 Brass - 1540E  
 Flushed - 1540EC  
 Stainless Steel - 1541  
 Stainless Steel Flushed - 1541C  
 December 2016

ITEM	PART NUMBER		DESCRIPTION		QTY	
	1540E 1540EC	MATL	1541 1541C	MATL		
300	<b>31770</b>	NBR	<b>31430</b>	NBR*	Kit, Seal (Incls: 98,106,112,125,155) (Standard)	1
	76430	FPM	76430	FPM	Kit, Seal (Incls: 98,106,112,125,155) (.0110)	1
310	<b>31775</b>	NBR	<b>31450</b>	NBR	Kit, Valve (Incls: 163,164,166,167,168,170,172) (Standard)	2
	<b>76775</b>	FPM	<b>76450</b>	FPM	Kit, Valve (Incls: 163,164,166,167,168,170,172) (.0110)	2
—	6107	—	6107	—	Oil, Bottle (21 oz. Bottles) ISO-68 Hydraulic (Fill to specified crankcase capacity prior to start-up)	2
—	—	—	<b>6119</b>	—	Lubricant, Antiseize (2 oz.) (See Tech Bulletin 095)	1
—	<b>701931</b>	—	—	—	Sealant, Silicone (See Tech Bulletin 100)	1

**Bold part numbers are unique to a particular pump model. Italics are optional items.**

† Production parts are different than replacement parts. R Components comply with RoHS Directive.  
 See Tech Bulletins 002, 003, 024, 035, 036, 043, 053, 074, 083, 095, 100 and 118 for additional information.

MATERIAL CODES (Not Part of Part Number): ABS=ABS Plastic ALE=Aluminum Epoxy BB=Brass CC=Ceramic CM=Chrome-moly F=Cast Iron FBB=Forged Brass FCM=Forged Chrome-moly  
 FPM=Fluorocarbon NBR=Medium Nitrile (Buna-N) NY=Nylon PE=Polyethylene PVDf=Polyvinylidene Fluoride S=304SS SHS=304SS/High Strength SS=316SS SNG=Special Blend (Buna)  
 STG=Special Blend PTFE White ST4=Special PTFE 4 STCP=Steel/Chrome Plated STL=Steel STZP=Steel/Zinc Plated TNM=Special High Strength

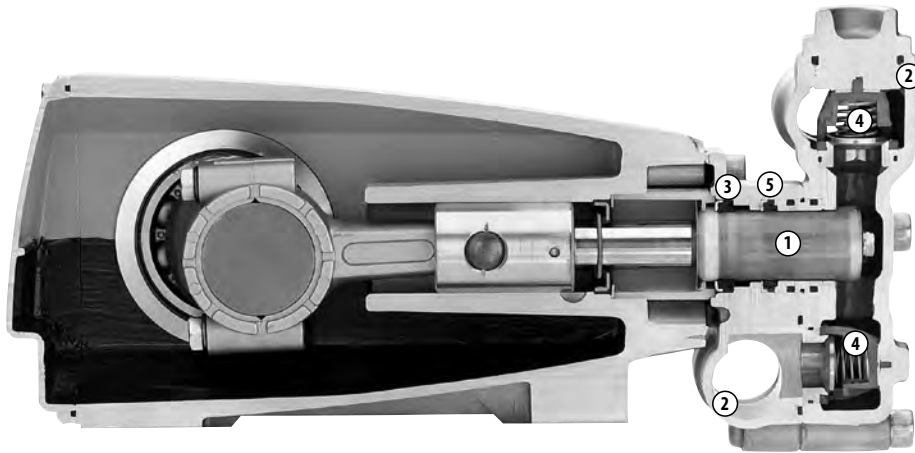
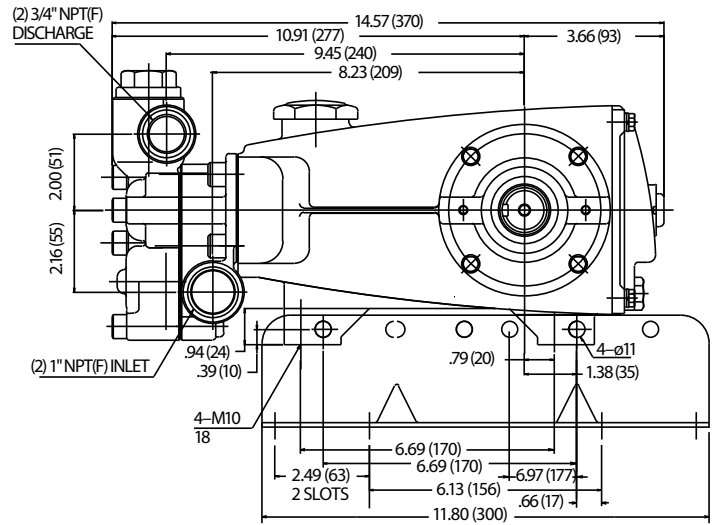
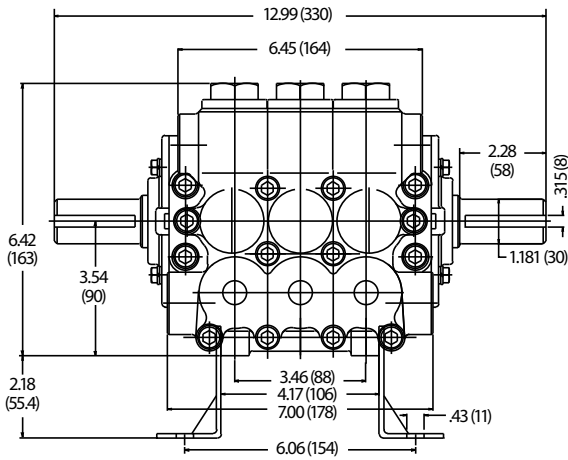

1. Special concentric, high-density, polished, solid ceramic **plungers** provide a true wear surface and extended seal life.
2. **Manifolds** are a high strength forged brass or stainless steel for long-term, continuous duty.
3. 100% wet **seal** design adds to service life by allowing pumped liquids to cool and lubricate on both sides of seals.
4. Stainless steel **valves, seats and springs** provide corrosion-resistance, ultimate seating and extended life.
5. Specially formulated, Cat Pump exclusive, **Hi-Pressure Seals** offer unmatched performance and seal life.
6. Special flushed **inlet manifolds** permits external flush for added cooling with high temperature liquids and lubrication with low lubricity liquids. (1540EC, 1541C) (Not Shown)

### ⚠ CAUTIONS AND WARNINGS

All High Pressure Systems require a primary pressure regulating device (i.e. regulator, unloader) and a secondary pressure relief device (i.e. pop-off valve, relief valve). Failure to install such relief devices could result in personal injury or damage to pump or property. Cat Pumps does not assume any liability or responsibility for the operation of a customer's high pressure system.

Read all CAUTIONS and WARNINGS before commencing service or operation of any high pressure system. The CAUTIONS and WARNINGS are included in each service manual and with each Accessory Data sheet. CAUTIONS and WARNINGS can also be viewed online at [www.catpumps.com/cautions-warnings](http://www.catpumps.com/cautions-warnings) or can be requested directly from Cat Pumps.

### WARRANTY

View the Limited Warranty on-line at [www.catpumps.com/warranty](http://www.catpumps.com/warranty).



### CAT PUMPS

1681 - 94TH LANE N.E. MINNEAPOLIS, MN 55449-4324  
 PHONE (763) 780-5440 — FAX (763) 780-2958  
 e-mail: [techsupport@catpumps.com](mailto:techsupport@catpumps.com)  
[www.catpumps.com](http://www.catpumps.com)