

DATA SHEET

25 FRAME PLUNGER PUMPS



Brass Model: **2510**

Stainless Steel Model: **2511**



Model 2510 Shown
(Rails and shaft protector sold separately)

FEATURES

- Triplex design delivers high efficiency and low pulsation.
- Durable dual V-Packings are lubricated and cooled by pumped liquid.
- Pre-set Lo-Pressure seals provide secondary protection against external leaks and require no packing adjustments.
- Standard NBR seals with alternative options for temperature and chemical compatibility.

COMMON SPECIFICATIONS

	U.S.	Metric
Pump RPM*	1450 rpm	1450 rpm
Inlet Pressure Range	Flooded to 70 psi	Flooded to 4.9 bar
Max. Liquid Temp. (NBR)	140°F	60°C
Alternative seals available for high temp up to 200° F		
Bore	0.984"	25 mm
Stroke	1.516"	38.5 mm
Crankcase Capacity	84 oz.	2.5 l
Inlet Ports (2)	1-1/4" NPT(F)	1-1/4" NPT(F)
Discharge Ports (2)	3/4" NPT(F)	3/4" NPT(F)
Pulley Mounting	Either side	Either side
Shaft Diameter	1.181"	30 mm
Weight (2510)	79 lbs.	36 kg
(2511)	75 lbs.	34 kg
Dimensions	20.45 x 15.04 x 8.46"	519 x 382 x 215 mm

*Pump minimum is 100 RPM.

SPECIFICATIONS

	U.S. Measure	Metric Measure
2510		
Flow	20 gpm	76 lpm
Pressure Range	100 to 2000 psi	6.9 to 138 bar
2511		
Flow	20 gpm	76 lpm
Pressure Range	100 to 1500 psi	6.9 to 103 bar

ALTERNATIVE SEAL CONFIGURATION

MATERIAL	SUFFIX CODE	MAXIMUM TEMPERATURE
NBR	—	160° F (71° C)
FPM	.0110	180° F (82° C)
EPDM	.0220	160° F (71° C)
STHT	.3400	200° F (93° C)

See Reference Document 99REF017 for inlet conditions and RPM at high temperature.

DETERMINING THE PUMP R.P.M.	Rated gpm	=	"Desired" gpm
	Rated rpm	=	"Desired" rpm
DETERMINING THE REQUIRED H.P.	Hp (Electric Brake)	=	gpm x psi 1460
	DETERMINING MOTOR PULLEY SIZE	Motor Pulley O.D. Pump rpm	=

Refer to pump Service Manual for repair procedure and additional technical information.

PARTS LIST

ITEM	PART NUMBER	MATL	PART NUMBER	MATL	DESCRIPTION	QTY
	2510		2511			
5	126544	STCP R	125753	S	Screw, HHC Sems (M8x25)	8
8	49533	ALE	49533	ALE	Cover, Bearing (See Tech Bulletin 118)	2
10	27772	NBR	27772	NBR	O-Ring, Bearing Cover - 70D	2
11	27771	NBR	27771	NBR	Seal, Oil, Crankshaft - 70D	2
15	26512	STL R	26512	STL R	Bearing, Ball	2
20	48613	TNM	48613	TNM	Rod, Connecting Assembly (Includes: Lockwasher, Washer, Screw)	3
21	126562	STCP R	126562	STCP R	Washer, Locking	3
25	49795	FCM	49795	FCM	Crankshaft, Dual-End	1
31	828710	PE	828710	PE	Protector, Oil Cap w/Foam Gasket	1
32	43211	ABS	43211	ABS	Cap, Oil Filler	1
33	14177	NBR	14177	NBR	O-Ring, Oil Filler Cap - 70D	1
36	129343	RBR	129343	RBR	Gasket, Flat	1
37	92241	—	92241	—	Gasket, Oil, Bubble w/Gasket - 80D	1
38	44428	NBR	44428	NBR	Gasket, Flat, Oil Guage - 80D	1
39	27769	ABS	27769	ABS	Dip Stick	1
40	126544	STCP R	125753	S	Screw, HHC Sems (M8x25)	8
48	25625	STCP	25625	STCP	Plug, Drain (1/4"x19BSP)	1
49	23170	NBR	23170	NBR	O-Ring, Drain Plug - 70D	1
50	133582	ALE	133582	ALE	Cover, Rear (See Tech Bulletin 118 and 126)	1
51	27767	NBR	27767	NBR	O-Ring, Rear Cover - 70D	1
53	49528	ALE	49528	ALE	Crankcase w/Guide Pins (See Tech Bulletin 118)	1
54	27488	S	27488	S	Pin, Guide	2
56	27790	POP	27790	POP	Pan, Oil	1
59	125824	STCP R	92538	S	Screw, HHC Sems (M6x16)	2
64	27784	CM	27784	CM	Pin, Crosshead	3
65	48719	SSHS	48719	SSHS	Rod, Plunger	3
70	27785	NBR	27785	NBR	Seal, Crankcase Oil - 70D	3
75	110669	S	110669	S	Slinger, Barrier	3
88	110670	S	110670	S	Washer, Keyhole	3
90	48535	CC	48535	CC	Plunger, Ceramic (M25x110)	3
95	126549	STCP R	48679	SS	Stud, Plunger Retainer (M7x103)	3
96	20184	PTFE	20184	PTFE	Back-up-Ring, Plunger Retainer	3
97	14190	NBR	14190	NBR	O-Ring, Plunger Retainer - 70D	3
98	44069	SS	44069	SS	Gasket, Plunger Retainer	3
99	44068	SS	44068	SS	Retainer, Plunger (M7)	3
100	49788	NY	49788	NY	Retainer, LPS, Front [03/11]	3
	49789	NY	49789	NY	Retainer, LPS, Rear [03/11]	3
101	48487	—	48487	—	Wick, Long Tab	3
106	44086	NBR	44086	NBR	Seal, LPS w/SS-Spg	3
107	48537	BB	48668	SS	Washer, LPS	3
110	48536	BBCP	48667	SS	Manifold, Inlet	1
112	11379	NBR	11379	NBR	O-Ring, Inlet Manifold - 70D	3
117	126510	STCP R	88398	S	Screw, HSH (M12x35 and M12x40)	4
126	48538	BB	48669	D	Adapter, Female	3
	—	—	76667	SS	Adapter, Female	3
127	44610	STG	44610	STG	V-Packing	6
128	48539	BB	113025	SS	Adapter, Male	3
141	48672	SS	48672	SS	Spring, Coil [12/02]	18
142	48550	BB	48670	SS	Spacer w/Coil Springs	3
155	17629	NBR	17629	NBR	O-Ring, Spacer-Rear - 80D	3
156	28243	PTFE	28243	PTFE	Back-up-Ring, Spacer-Rear	3
158	28243	PTFE	28243	PTFE	Back-up-Ring, Spacer-Front	3
159	17629	NBR	17629	NBR	O-Ring, Spacer-Front - 80D	3
162	48363	D	48363	D	Back-up-Ring, Seat	6
163	26142	NBR	26142	NBR	O-Ring, Seat - 80D	6
164	48544	S	48676	SS	Seat	6
166	45839	SS	45839	SS	Valve	6
167	45840	SS	45840	SS	Spring	6
168	110682	PVDF	110682	PVDF	Retainer, Spring	6
170	44794	SS	44794	SS	Washer, Spring Retainer	6
171	48689	SS	48689	SS	Spring, Coil [12/02]	6
172	17667	NBR	17667	NBR	O-Ring, Valve Plug - 80D	6
174	120693	BBCP	49295	SS	Plug, Valve (w/O-Ring Model 2510 Only)	6
185	48543	BBCP	48674	SS	Manifold, Discharge	1
188	126511	STCP R	88399	S	Screw, HSH (M12x80)	6

Bold part numbers are unique to a particular pump model. Italics are optional items. [] Date of latest production change.

R Components comply with RoHS Directive. * Review material codes for individual items (STG generally may be used as alternate).

See Tech Bulletins 024, 035, 036, 043, 074, 083, 085, 095, 118 and 126 for additional information.

MATERIAL CODES (Not Part of Part Number): ABS=ABS Plastic ALE=Aluminum Epoxy BB=Brass BBCP=Brass/Chrome Plated CC=Ceramic CM=Chrome-Moly D=Acetal FCM=Forged Chrome-Moly FPM=Fluorocarbon NBR=Medium Nitrile (Buna-N) NY=Nylon PE=Polyethylene POP=Polypropylene PTFE=Pure Polytetrafluoroethylene PVDF=Polyvinylidene Fluoride S=304SS SS=316SS/High Strength STCP=Steel/Chrome Plated STG=Special Blend PTFE White STHT=Special PTFE High Temp STL=Steel ST2=Special PTFE 2 STZP=Steel/Zinc Plated TNM=Special High Strength

Standard and optional Seal Kits and Valve Kits listed on pages 3 and 4. Optional Parts and Accessories and Service parts listed on Page 3.

EXPLODED VIEW

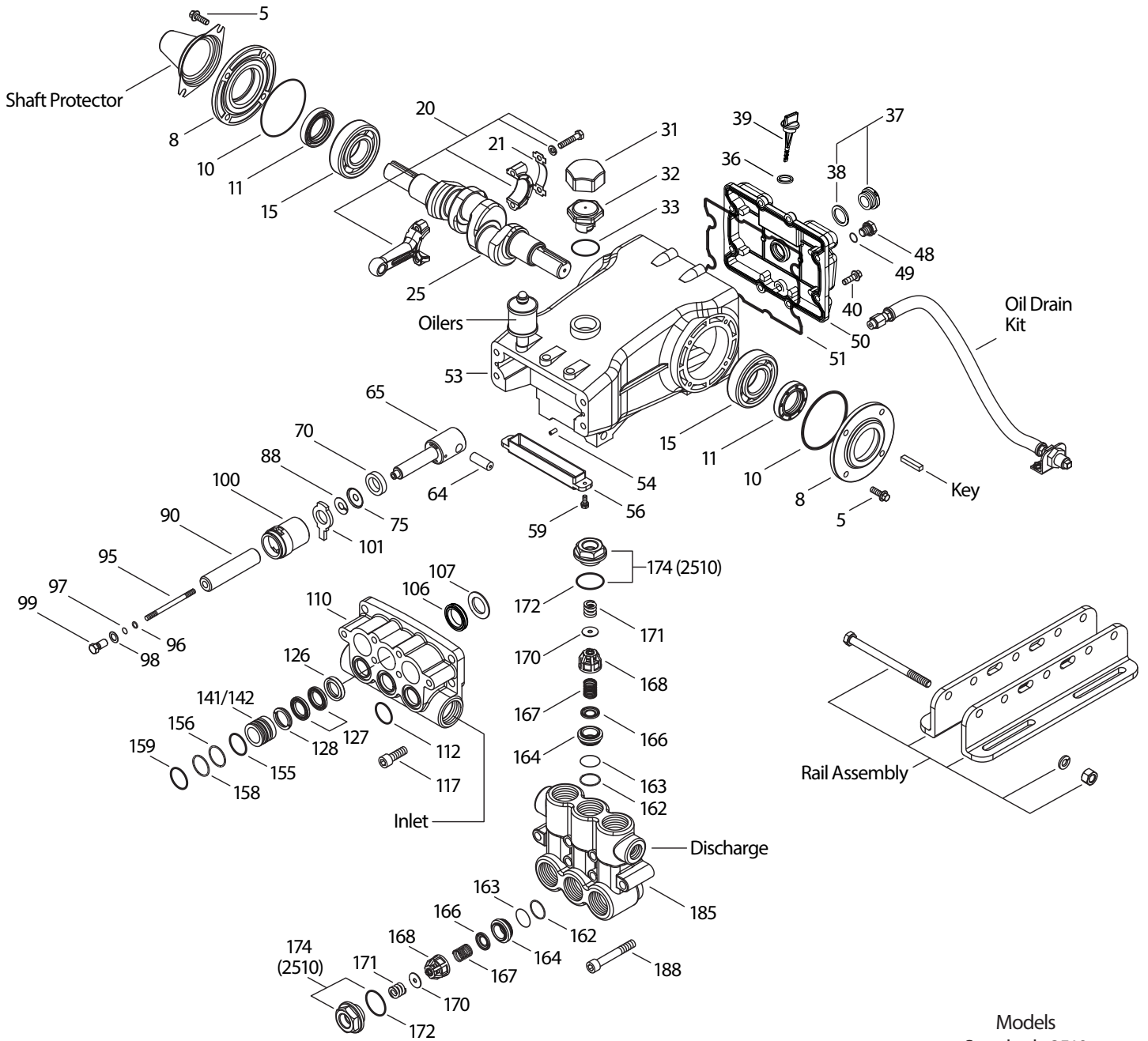

Models
Standard - 2510
Stainless Steel - 2511
January 2019

OPTIONAL PARTS AND ACCESSORIES

PART	DESCRIPTION	QTY
31280	Seal Kit - Standard NBR 2510	1
76180	Seal Kit - Standard NBR 2511	1
31285	Valve Kit - Standard NBR 2510	2
31270	Valve Kit - Standard NBR 2511	2
30614	Mount, Rail Assembly	1
26516	Protector, Shaft	1
30278	Oiler (1 oz)	3
34334	Kit, Oil Drain	1
30696	Plier, Reverse	1
34314	Kit, Oil Drain	1
30696	Plier, Reverse (Not Shown)	1

SERVICE PARTS

PART	DESCRIPTION	QTY
6100	Oil, Case (12 - 21 oz. bottle)	1
990036	Key, M8 x 7 x 40	1
6119	Lubricant, Anti-Seize (2 oz) (2511)	1
6124	Gasket, Liquid (3 oz)	1
816747	Head, Complete - 2510 w/NBR Seals and O-Rings	1
816785	Head, Complete - 2511 w/NBR Seals and O-Rings	1

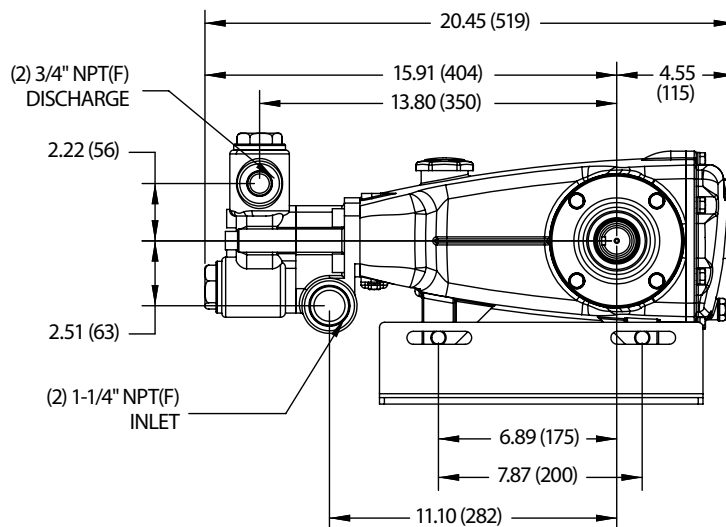
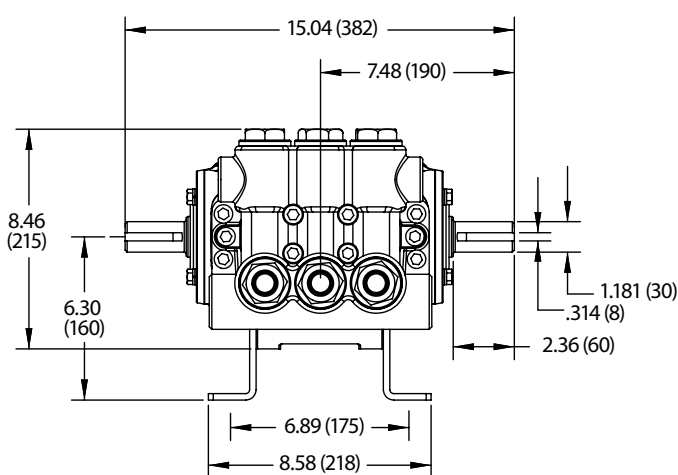

SEAL KITS One (1) seal kit required per pump

PUMP MODELS	NBR (STD)	FPM (.0110)	EPDM (.0220)◆	STHT (.3400)
2510	31280 *	31380 *	76200 *	76376
2511	76180	31380 *	76200 *	76376

ITEM (Included in Seal Kits)					DESCRIPTION	QTY
97	14190	14161	48239	14190	O-Ring, Plunger Retainer	3
106	44086	45846	49196	76086	Seal, LPS w/SS-Spg	3
112	11379	14183	701491	11379	O-Ring, Inlet Manifold	3
126	48669		48669		Adapter, Female	3
127	44610	44610	44610	44610	V-Packing	6
155	17629	14183	701491	17629	O-Ring, Spacer, Rear	3
156	28243	28243	28243	28243	Backup-Ring, Spacer, Rear	3
158	28243	28243	28243	28243	Backup-Ring, Spacer, Front	3
159	17629	14183	701491	17629	O-Ring, Spacer, Front	3

◆ Silicone oil/grease required *Review material codes for individual items (STG generally by be used as alternative)

VALVE KITS Two (2) valve kits required per pump

PUMP MODELS	NBR (STD)	FPM (.0110)	EPDM (.0220)◆
2510	31285	31385	76197
2511	31270	31275	76370

ITEM (Included in Valve Kits)				DESCRIPTION	QTY
162	48363	48363	48363	Backup-Ring, Valve Seat	3
163	26142	14330	701493	O-Ring, Valve Seat	3
164	48544	48544	48544	Seat, Stepped (2510)	3
	48676	48676	48676	Seat, Stepped (2511)	3
166	45839	45839	45839	Valve	3
167	45840	45840	45840	Spring	3
168	110682	110682	110682	Retainer, Spring	3
170	44794	44794	44794	Washer, Spring Retainer	3
172	17667	11745	48240	O-Ring, Valve Plug	3

◆ Silicone oil/grease required

⚠ CAUTIONS AND WARNINGS

All High Pressure Systems require a primary pressure regulating device (i.e. regulator, unloader) and a secondary pressure relief device (i.e. pop-off valve, relief valve). Failure to install such relief devices could result in personal injury or damage to pump or property. Cat Pumps does not assume any liability or responsibility for the operation of a customer's high pressure system.

Read all CAUTIONS and WARNINGS before commencing service or operation of any high pressure system. The CAUTIONS and WARNINGS are included in each service manual and with each Accessory Data sheet. CAUTIONS and WARNINGS can also be viewed online at www.catpumps.com/cautions-warnings or can be requested directly from Cat Pumps.

WARRANTY

View the Limited Warranty on-line at www.catpumps.com/warranty.