

DATA SHEET

28 FRAME BLOCK-STYLE PLUNGER PUMPS



Stainless Steel Model: **2831**

Flushed Stainless Steel Model: **2831K**



Model 2831 Shown
(Mounting rails sold separately)

FEATURES

- Triplex design delivers high efficiency and low pulsation.
- Lo-Pressure Seals and V-Packings are completely lubricated and cooled by the liquid being pumped.
- Special flushed inlet manifold on Model 2831K permits an external flush for added cooling with high temperature liquids or lubrication with low lubricity liquids.
- Standard NBR seals with alternative options for temperature and chemical compatibility.

COMMON SPECIFICATIONS

	U.S.	Metric
Inlet Pressure Range	Flooded to 70 psi	Flooded to 4.8 bar
Bore	1.260"	32 mm
Stroke	1.516"	38.5 mm
Crankcase Capacity	84 oz.	2.5 l
Max. Liquid Temp. (NBR)	160° F	71° C

Alternative seals available for high temp up to 200° F

Inlet Ports (2)	1 1/4" NPT(F)	1 1/4" NPT(F)
Flush Ports (2)	1/4" NPT(F)	1/4" NPT(F)
Discharge Ports (2)	3/4" NPT(F)	3/4" NPT(F)
Pulley Mounting	Either Side	Either Side
Shaft Diameter	1.181"	30 mm
Weight	104 lbs.	42.7 kg
Dimensions	18.98 x 15.04 x 8.11"	482 x 382 x 206 mm

SPECIFICATIONS

	U.S. Measure	Metric Measure
Flow	25 gpm	95 lpm
Pressure Range	100 to 1200 psi	6.9 to 83 bar
Pump RPM*	1025 rpm	1025 rpm

*Pump minimum is 100 RPM

ALTERNATIVE SEAL CONFIGURATION

MATERIAL	SUFFIX CODE	MAXIMUM TEMPERATURE	
NBR	—	160° F	(71° C)
FPM	.0110	180° F	(82° C)
EPDM	.0220	160° F	(71° C)
HT	.3000	180° F	(82° C)
STHT	.3400	200° F	(93° C)

See Reference Document 99REF017 for inlet conditions and RPM at high temperature.

DETERMINING THE PUMP R.P.M.

$$\frac{\text{Rated gpm}}{\text{Rated rpm}} = \frac{\text{"Desired" gpm}}{\text{"Desired" rpm}}$$

DETERMINING THE REQUIRED H.P.

$$\text{Hp (Electric Brake)} = \frac{\text{gpm} \times \text{psi}}{1460}$$

DETERMINING MOTOR PULLEY SIZE

$$\frac{\text{Motor Pulley O.D.}}{\text{Pump rpm}} = \frac{\text{Pump Pulley O.D.}}{\text{Motor rpm}}$$

Refer to pump **Service Manual** for repair procedure and additional technical information.

PARTS LIST

ITEM	PART NUMBER				DESCRIPTION	QTY
	2831	MATL	2831K	MATL		
2	990036	STL	990036	STL	Key (M8x7x40) [2/00]	1
5	125753	S	125753	S	Screw, Sems HHC (M8x25)	8
8	49533	ALE	49533	ALE	Cover, Bearing (See Tech Bulletin 118)	2
10	27772	NBR	27772	NBR	O-Ring, Cover, Bearing - 70D	2
11	27771	NBR	27771	NBR	Seal, Oil, Crankshaft - 70D	2
15	26512	STL	26512	STL	Bearing, Ball	2
20	48613	TNM	48613	TNM	Rod, Connecting	3
21	126562	STCP R	126562	STCP R	Washer, Locking	3
25	49795	FCM	49795	FCM	Crankshaft, Dual End [3/11]	1
31	828710	PE	828710	PE	Protector, Oil Cap	1
32	43211	ABS	43211	ABS	Cap, Oil Filler	1
33	14177	NBR	14177	NBR	O-Ring, Oil Filler Cap - 70D	1
38	129343	RBR	129343	RBR	Gasket, Dipstick - 70D	1
39	27769	ABS	27769	ABS	Dipstick	1
40	125753	S	125753	S	Screw, Sems HHC (M8x25)	8
48	25625	STCP	25625	STCP	Plug, Drain (1/4"x19 BSP)	1
49	23170	NBR	23170	NBR	O-Ring, Drain Plug - 70D	1
50	49531	ALE	49531	ALE	Cover, Rear (See Tech Bulletin 118)	1
51	27767	NBR	27767	NBR	O-Ring, Rear Cover - 70D	1
53	49528	ALE	49528	ALE	Crankcase w/Guide Pins (See Tech Bulletin 118)	1
54	27488	S	27488	S	Pin, Guide	2
64	27784	CM	27784	CM	Pin, Crosshead	3
65	48719	SSHS	48719	SSHS	Rod, Plunger	3
70	27785	NBR	27785	NBR	Seal, Crankcase, Oil - 70D	3
75	110669	S	110669	S	Slinger, Barrier	3
88	110670	S	110670	S	Washer, Keyhole	3
90	45749	CC	45749	CC	Plunger (M32x93)	3
95	89835	SS	89835	SS	Stud, Retainer, (M7x87)	3
96	20184	PTFE	20184	PTFE	Back-up-Ring, Plunger Retainer	3
97	14190	NBR	14190	NBR	O-Ring, Plunger Retainer - 70D	3
	14161	FPM	14161	FPM	O-Ring, Plunger Retainer - 70D	3
	◆ 48239	EPDM	◆ 48239	EPDM	O-Ring, Plunger Retainer	3
98	44069	SS	44069	SS	Gasket, Plunger Retainer	3
99	44068	SS	44068	SS	Retainer, Plunger (M7)	3
100	49788	NY	49788	NY	Retainer, LPS Front	3
	49789	NY	49789	NY	Retainer, LPS Rear	3
106	44098	NBR	44098	NBR	Seal, LPS w/SS-Spg	3
	44827	FPM	44827	FPM	Seal, LPS w/SS-Spg	3
	◆ 48244	EPDM	◆ 48244	EPDM	Seal, LPS w/SS-Spg	3
	76298	ST2	76298	ST2	Seal, LPS	3
110	701661	SS	—	—	Manifold, Inlet Block-Style	1
	—	—	701719	SS	Manifold, Inlet Block-Style, Flushed [1/4" NPT(F)] Ports	1
111	701104	SS	701104	SS	Plug, Inlet Manifold, [1-1/4" NPT(M)]	1
117	701693	S	701693	S	Screw HSH (M12x80)	4
118	701077	SS	—	—	Plug, [1/4" NPT(M)]	3
125	45832	SNG	45832	SNG	Seal, HPS w/SS	3
	48220	HT	48220	HT	Seal, HPS w/SS, 2-PC w/S-Support	3
143	14200	NBR	14200	NBR	O-Ring, Valve Adapter, Rear - 70D	6
	11719	FPM	11719	FPM	O-Ring, Valve Adapter, Rear	6
	◆ 701654	EPDM	◆ 701654	EPDM	O-Ring, Valve Adapter, Rear - 80D	6
144	28243	PTFE	28243	PTFE	Back-up-Ring, Valve Adapter	6
150	701675	SS	701675	SS	Adapter, Valve	6
154	11379	NBR	11379	NBR	O-Ring, Valve Adapter, Front - 70D	6
	14183	FPM	14183	FPM	O-Ring, Valve Adapter, Front	6
	◆ 701491	EPDM	◆ 701491	EPDM	O-Ring, Valve Adapter, Front - 70D	6
155	14520	NBR	14520	NBR	O-Ring, Seal Spacer - 70D	6
	11745	FPM	11745	FPM	O-Ring, Seal Spacer - 70D	6
	◆ 48240	EPDM	◆ 48240	EPDM	O-Ring, Seal Spacer	6
157	701692	SS	701692	SS	Spacer, HPS	3
162	21985	PTFE	21985	PTFE	Back-up-Ring, Seat	6
163	26089	NBR	26089	NBR	O-Ring, Seat - 80D	6
	11377	FPM	11377	FPM	O-Ring, Seat - 80D	6
	◆ 46647	EPDM	◆ 46647	EPDM	O-Ring, Seat - 80D	6
164	44080	SS	44080	SS	Seat	6
166	44081	SS	44081	SS	Valve	6
167	44082	SS	44082	SS	Spring	6
168	44735	PVDF	44735	PVDF	Retainer, Spring	6
170	44794	SS	44794	SS	Washer, Spring Retainer	6
172	700008	NBR	700008	NBR	O-Ring, Valve Plug	3
	700048	FPM	700048	FPM	O-Ring, Valve Plug	3
	◆ 701782	EPDM	◆ 701782	EPDM	O-Ring, Valve Plug	3
174	701694	SS	701694	SS	Plug, Valve	3
185	701662	SS	701662	SS	Manifold, Valve, Block-Style	1
188	89628	S	89628	S	Screw HSH (M12x65)	16
250	26516	STCP	26516	STCP	Protector, Shaft	1
260	30614	STZPR	30614	STZPR	Mount, Rail, Assy	1
269	30206	F	30206	F	Pulley, 10" 2 groove "H" [See Tech Bulletin 003] [Not Shown]	1
270	30059	STL	30059	STL	Hub, "H", M30 [See Tech Bulletin 003] [Not Shown]	1
283	34334	—	34334	—	Kit, Oil Drain (3/8" x 24") (See Individual Data Sheet)	1

EXPLODED VIEW

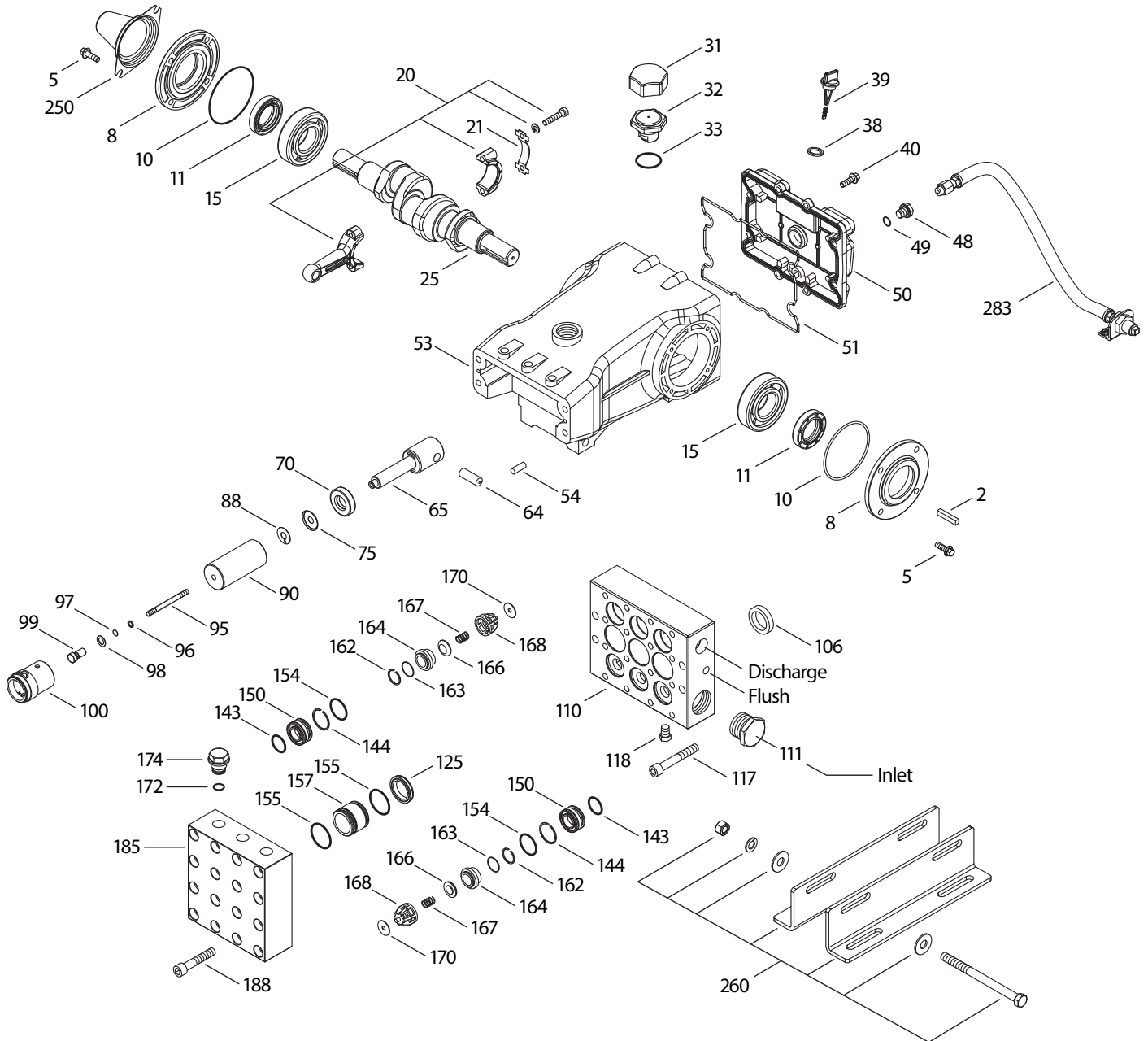

Models
2831, 2831K
August 2018

ITEM	PART NUMBER		DESCRIPTION		QTY	
	2831	MATL	2831K	MATL		
290	6124	—	6124	—	Gasket, Liquid (3 oz.) [See Tech Bulletin 053]	1
299	901402	SS	—	—	Head, Complete, Block-Style w/NBR Seals and O-Rings	1
—	—	—	901403	SS	Head, Complete, Block-Style, Flushed w/NBR Seals and O-Rings	1
300	701731	NBR	701731	NBR	Kit, Seal (Incls: 96,97,106,125,143,144,154,155) Standard	1
—	701806	FPM	701806	FPM	Kit, Seal (Incls: 96,97,106,125,143,144,154,155) .0110	1
◆	33604	EPDM	◆ 33604	EPDM	Kit, Seal (Incls: 96,97,106,125,143,144,154,155) .0220	1
310	701732	NBR	701732	NBR	Kit, Valve (Incls: 143,144,154,155,162,163,164,166,167,168,170,172) Standard	2
—	701807	FPM	701807	FPM	Kit, Valve (Incls: 143,144,154,155,162,163,164,166,167,168,170,172) .0110	2
◆	701796	EDPM	◆ 701796	EPDM	Kit, Valve (Incls: 143,144,154,155,162,163,164,166,167,168,170,172) .0220	2
370	—	—	990663	—	Assembly, Flushing, 5 gal, 115V, 1.1 Amp, 1/2" NPT	1
—	6119	—	6119	—	Lubricant, Antiseize (2 oz.) (See Tech Bulletin 095)	1
—	6100	—	6100	—	Oil, Case (12 Bottles) ISO 68 Hydraulic (Fill to specified crankcase capacity prior to start-up)	1

Bold print part numbers are unique to a particular pump model. Italics are optional items. ◆ Silicone oil/grease required.

[] Date of latest production change. See Tech Bulletins 024, 036, 043, 053, 074, 083, 085, 095 and 118 for additional information.

MATERIAL CODES (Not Part of Part Number): ABS=ABS Plastic AL=Aluminum ALE=Aluminum Epoxy CC=Ceramic CM=Chrome-moly EPDM=Ethylene Propylene Diene Monomer F=Cast Iron FCM=Forged Chrome-moly FPM=Fluorocarbon HT=High Temp NBR=Medium Nitrile (Buna-N) NY=Nylon PE=Polyethylene PTFE=Pure Polytetrafluoroethylene PVDF=Polyvinylidene Fluoride RBR=Rubber S=304SS SS=316SS SNG=Special Blend (Buna) STZ=Special PTFE 2 SSHS=316SS/High Strength STCP=Steel/Chrome Plated STL=Steel STZP=Steel/Zinc Plated TNM=Special High Strength

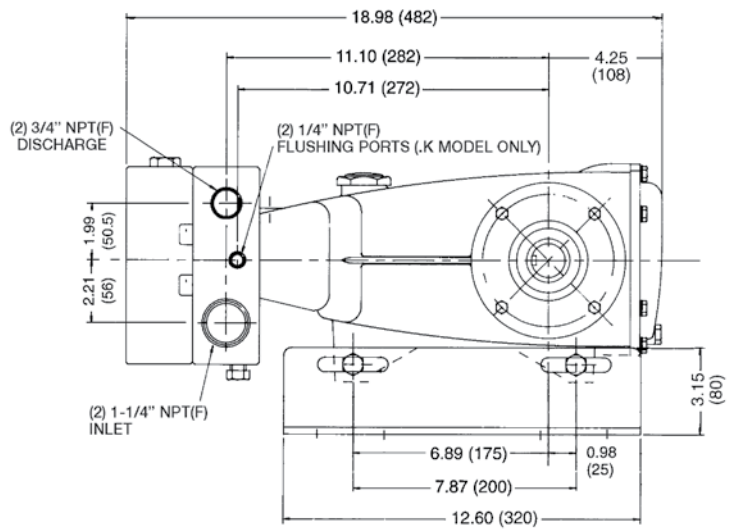
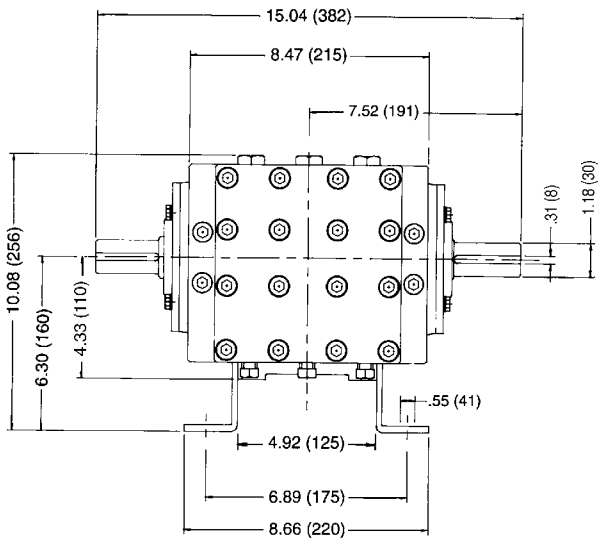

Model 2831

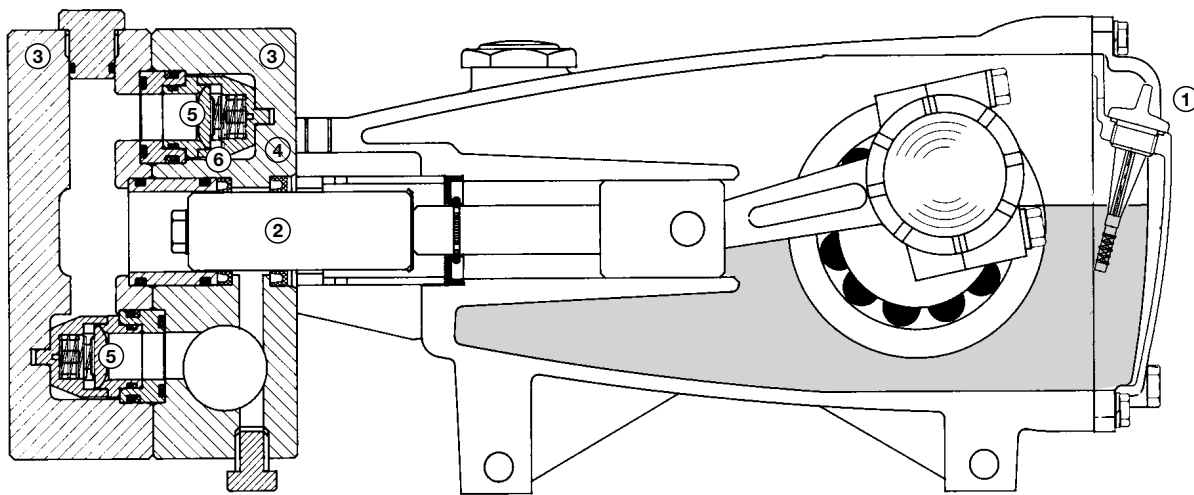

- 1 Dipstick offers convenient top access for easy oil level check.
- 2 Special concentric, high-density, polished, solid ceramic plungers provide a true wear surface and extended seal life.
- 3 Manifolds are 316 SS block-style for long-term, continuous-duty and corrosion resistance.
- 4 Flushed Models: Special ported inlet manifold permits liquid to cool or flush between Hi-Pressure and Lo-Pressure Seals providing protection against high temperatures or contaminating pumped liquids.
- 5 316 stainless steel valves, seats and springs provide corrosion-resistance, ultimate seating and extended life.
- 6 Specially formulated, Cat Pump exclusive, Hi-Pressure Seals offer unmatched performance and seal life.

⚠ CAUTIONS AND WARNINGS

All High Pressure Systems require a primary pressure regulating device (i.e. regulator, unloader) and a secondary pressure relief device (i.e. pop-off valve, relief valve). Failure to install such relief devices could result in personal injury or damage to pump or property. Cat Pumps does not assume any liability or responsibility for the operation of a customer's high pressure system. Read all CAUTIONS and WARNINGS before commencing service or operation of any high pressure system. The CAUTIONS and WARNINGS are included in each service manual and with each Accessory Data sheet. CAUTIONS and WARNINGS can also be viewed online at www.catpumps.com/cautions-warnings or can be requested directly from Cat Pumps.

WARRANTY

View the Limited Warranty on-line at www.catpumps.com/warranty.