

# DATA SHEET

## DIRECT DRIVE PLUNGER PUMPS



**Brass Electric Models:**

**2SF10ES, 2SF20ES, 2SF22ES, 2SF22ELS, 2SF29ELS, 2SF30ES, 2SF35ES**

**Brass Gas Models:**

**2SF30GS, 2SF35GS**

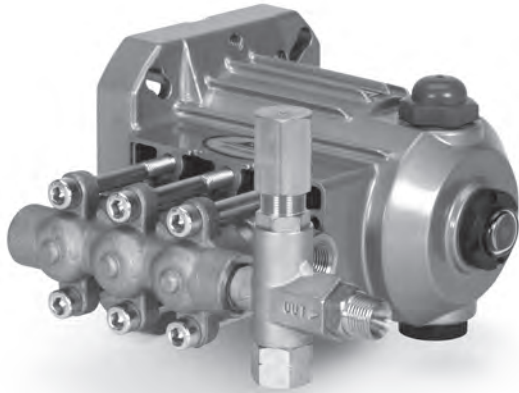

Model 2SF10ES Shown  
(Unloader included with pump)

### FEATURES

- Your choice of motorized unit or hollow shaft pumps only for direct mounting to gas engine or electric motor.
- Includes regulating unloader to assure system pressure control and pump protection.
- Standard NBR seals with alternative options for temperature and chemical compatibility.

### COMMON SPECIFICATIONS

	U.S.	Metric
Inlet Pressure Range (Standard)	Flooded to 75 psi	Flooded to 5.2 bar
Inlet Pressure Range (High-Temp)	30 to 75 psi	2.1 to 5.2 bar
Max. Liquid Temperature (NBR)	160°F	71°C
<b>Alternate seals available for high temperature up to 180° F</b>		
Bore	0.708"	18 mm
Crankcase Capacity	10.1 oz.	0.3 l
Inlet Port (1)	3/8" NPT(F)	3/8" NPT(F)
Discharge Port (1)	3/8" NPT(F)	3/8" NPT(F)
Discharge Port (1)	3/8" NPT(M)	3/8" NPT(M)
By-pass Port (1)	1/4" NPT(F)	1/4" NPT(F)
Weight (Pump Only)	10.6 lbs.	4.8 kg
Dimensions (Pump Only)	9.13 x 6.65 x 6.50"	232 x 169 x 165 mm

SPECIFICATIONS	U.S. Measure	Metric Measure	U.S. Measure	Metric Measure
	<b>2SF10ES</b>		<b>2SF20ES</b>	
Flow	1.0 gpm	3.8 lpm	2.0 gpm	7.6 lpm
Max. Discharge Pressure	2000 psi	138 bar	2000 psi	138 bar
Pump RPM	3450 rpm	3450 rpm	3450 rpm	3450 rpm
Stroke	0.071"	1.8 mm	0.122"	3.1 mm
	<b>2SF22ELS</b>		<b>2SF22ES</b>	
Flow	2.2 gpm	8.3 lpm	2.2 gpm	8.3 lpm
Max. Discharge Pressure	2000 psi	138 bar	2000 psi	138 bar
Pump RPM	1725 rpm	1725 rpm	3450 rpm	3450 rpm
Stroke	0.248"	6.3 mm	0.132"	3.35 mm
	<b>2SF29ELS</b>		<b>2SF30ES</b>	
Flow	2.85 gpm	10.8 lpm	3.0 gpm	11.4 lpm
Max. Discharge Pressure	1500 psi	103 bar	1500 psi	103 bar
Pump RPM	1725 rpm	1725 rpm	3450 rpm	3450 rpm
Stroke	0.335"	8.5 mm	0.177"	4.5 mm
	<b>2SF30GS</b>			
Flow	3.0 gpm	11.4 lpm		
Max. Discharge Pressure	2000 psi	138 bar		
Pump RPM	3450 rpm	3450 rpm		
Stroke	0.189"	4.8 mm		
	<b>2SF35ES</b>		<b>2SF35GS</b>	
Flow	3.5 gpm	13.2 lpm	3.5 gpm	13.2 lpm
Max. Discharge Pressure	1500 psi	103 bar	2000 psi	138 bar
Pump RPM	3450 rpm	3450 rpm	3450 rpm	3450 rpm
Stroke	0.220"	5.6 mm	0.220"	5.6 mm
Optional Electric-3/4" Shaft - 2SF30GES, 2SF35GES				

ES = **Electric 5/8"** hollow shaft with bolt mount, NEMA 56C  
 GES = **Electric 3/4"** hollow shaft with bolt mount.  
 GS = **Gas 3/4"** hollow shaft with bolt mount and adapter.  
 Gas Mounting Flange: SAE J609, Flange A, Extension 3 (3/4" Ø)  
 Shaft Length = 2.296, Pilot Ø = 1 5/8", B.C. Ø = 3 5/8", Thread = 5/16"- 24 UNC Tap  
 Refer to pump **Service Manual** for repair procedures and additional technical information.

### ALTERNATIVE SEAL CONFIGURATION

MATERIAL	SUFFIX CODE	MAXIMUM TEMPERATURE	
NBR	—	160° F	(71° C)
FPM	.0110	180° F	(82° C)
EPDM	.0220	160° F	(71° C)
HT	.3000	180° F	(82° C)

See Reference Document 99REF017 for inlet conditions and RPM at high temperature.

# PARTS LIST

ITEM	PART NUMBER	MATL	DESCRIPTION	MODEL USED	QTY
5	549360	STCP R	Screw, HH (M6x 14) (See Tech Bulletin 092)	All Models	3
8	547153	AL	Cover, Bearing, Inner (See Tech Bulletin 092)	All Models	1
10	14041	NBR	O-Ring, Bearing Cover - 70D (See Tech Bulletin 092)	All Models	1
11	55337	NBR	Seal, Oil (See Tech Bulletin 092)	All Models	1
15	14488	STL	Bearing, Ball, Inner	All Models	1
20	547046	TNM	Rod, Connecting	All Models	3
25	<b>831987</b>	CM	Crankshaft, 3450 RPM, 5/8", 1.8mm	2SF10ES	1
	<b>46109</b>	CM	Crankshaft, 3450 RPM, 5/8", 3.1mm	2SF20ES	1
	<b>45962</b>	CM	Crankshaft, 3450 RPM, 5/8", 3.35mm	2SF22ES	1
	<b>546334</b>	CM	Crankshaft, 3450 RPM, 3/4", 4.8mm	2SF30GS	1
	<b>44931</b>	CM	Crankshaft, 3450 RPM, 5/8", 4.5mm	2SF30ES	1
	<b>45096</b>	CM	Crankshaft, 3450 RPM, 5/8", 5.6mm	2SF35ES	1
	<b>46017</b>	CM	Crankshaft, 3450 RPM, 3/4", 5.6mm	2SF35GS	1
	<b>45160</b>	CM	Crankshaft, 1725 RPM, 5/8", 6.3mm	2SF22ELS	1
	<b>45914</b>	CM	Crankshaft, 1725 RPM, 5/8", 8.5mm	2SF29ELS	1
26	12385	STL	Ring, Retaining	All Models	1
27	15710	STL	Bearing, Ball, Outer	All Models	1
31	549726	—	Cap, Vented w/O-Ring (Rain Cap)	All Models	1
32	547961	RTP	Cap, Oil Filler w/O-Ring	All Models	1
33	14179	NBR	O-Ring, Oil Filler Cap - 70D	All Models	1
37	92241	—	Gauge, Bubble Oil w/Gasket - 80D	All Models	1
38	44428	NBR	Gasket, Flat Flex., Oil Gauge - 80D	All Models	1
48	44842	NY	Plug, Drain [1/2" NPT(F)]	All Models	1
49	14179	NBR	O-Ring, Drain Plug - 70D	All Models	1
53	547285	AL	Crankcase (See Tech Bulletin 092)	All Models	1
64	16948	CM	Pin, Crosshead	All Models	3
65	<b>44865</b>	SCP	Rod, Plunger	All Models except 2SF29ELS	3
	<b>45427</b>	SZZ	Rod, Plunger	2SF29ELS	3
69	126259	STCP R	Washer (M24)	All Models	3
70	25461	NBR	Seal, Oil	All Models	3
90	<b>45847</b>	CC	Plunger (M18x14)	All Models except 2SF29ELS	3
	<b>45429</b>	CC	Plunger (M18x16)	2SF29ELS	3
100	44869	PVDF	Retainer, Seal	All Models	3
106	44876	NBR	Seal, LPS w/S-Spg	All Models	3
	545192	FPM	Seal, LPS w/SS-Spg	All Models	3
	◆ 546507	EPDM	Seal, LPS w/SS-Spg	All Models	3
110	44874	BB	Manifold, Inlet	All Models	1
125	43245	SNG	Seal, HPS w/S	All Models	3
	46652	HT	Seal, HPS "Hi-Temp" 2-Pc w/S-Support	All Models	3
	76052	ST4	Seal, HPS w/S	All Models	3
134	45854	S	Valve, Inlet	All Models	3
	33873	D	Valve, Inlet, Hi-Temp	All Models	3
135	549520	S	Spacer, Inlet	All Models	3
136	44872	S	Spring, Inlet Valve	All Models	3
137	88575	S	Washer, Conical (M6)	All Models	3
138	27000	S	Nut, Slotted (M6)	All Models	3
139	14158	S	Cotterpin (M1.6x10)	All Models	3
152	26089	NBR	O-Ring, Adapter, Inner - 80D	All Models	3
	11377	FPM	O-Ring, Adapter, Inner - 80D	All Models	3
	◆ 46647	EPDM	O-Ring, Adapter, Inner - 80D	All Models	3
157	<b>44878</b>	BB	Discharge Valve Adapter	All Models except 2SF29ELS	3
	<b>45430</b>	BB	Discharge Valve Adapter	2SF29ELS	3
159	26089	NBR	O-Ring, Adapter, Outer - 80D	All Models	3
	11377	FPM	O-Ring, Adapter, Outer - 80D	All Models	3
	◆ 46647	EPDM	O-Ring, Adapter, Outer - 80D	All Models	3
164	44881	S	Seat	All Models	3
166	43723	S	Valve	All Models	3
167	541062	S	Spring	All Models	3
168	44565	PVDF	Retainer, Spring	All Models	3
185	44879	BB	Manifold, Discharge	All Models	1
188	126762	STCP R	Screw, HSH (M8x75)	All Models	6
197	941516	BB	GH Assembly, 3/8" NPT(M) x 3/4" GH(F)	All Models	1
249	30520	—	Assy, Adapter Mount, Gas	2SF30GS, 2SF35GS	1
255	30517	STZP R	Assy, Bolt Mount	All Models	1

# EXPLODED VIEW

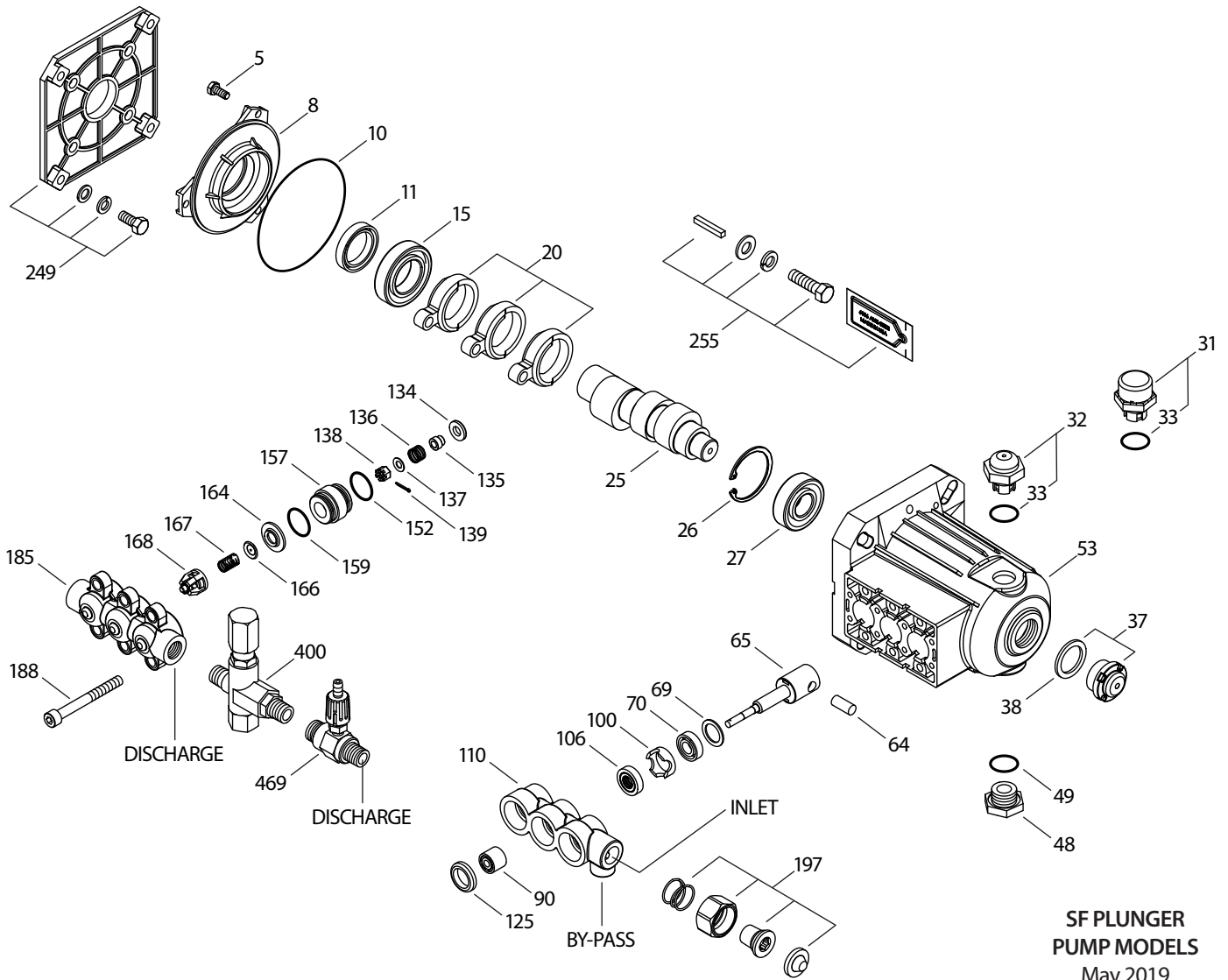

**SF PLUNGER  
PUMP MODELS**  
May 2019

ITEM	PART NUMBER	MATL	DESCRIPTION	MODEL USED	QTY
285	80228	STL	Screw (M8-1.25x80) (Not Shown)	All Models	2
300	34053	NBR	Kit, Seal (Incls: 106,125,139,152, 159) <b>Standard</b>	All Models	1
	33953	HT	Kit, Seal-Hi-Temp (Incls: 106,125,134,139,152,159) <b>.3000</b>	All Models	1
	33453	FPM	Kit, Seal (Incls: 106,125,139,152, 159) <b>.0110</b>	All Models	1
◆	30536	EPDM*	Kit, Seal (Incls: 106,125,139,152, 159) <b>.0220</b>	All Models	1
310	34052	NBR	Kit, Discharge Valve (Incls: 152,159,164,166,167,168) <b>Standard, .3000</b>	All Models	1
311	34668	NBR	Kit, Inlet Valve (Incls: 134-139,152,159) <b>Standard</b>	All Models	1
400	75005	BB	Unloader, Regulating	All Models	1
469	7192	BB	Injector, Chemical (1.8 mm Adjustable)	All Models	1
—	7193	BB	Injector, Chemical (2.1 mm Adjustable)	All Models	1
—	7194	BB	Injector, Chemical (2.3 mm Adjustable)	All Models	1
—	6107	—	Oil, Bottle (21 oz) ISO 68 Hydraulic (Fill to specified crankcase capacity prior to start-up)	All Models	1

**Bold print part numbers are unique to a particular pump model.** *Italics are optional items.* [ ] Date of latest production change. R Components comply with RoHS Directive.

\*Review individual parts in each kit for material code identification ◆ Silicone Oil/Grease Required.

View Tech Bulletins 024, 036, 043, 055, 064, 065, 070, 073, 074, 083, 091 and 092 for additional information.

NOTE: Discard Key which may come standard with most motors and engines and **use only the key included in this kit.**

MATERIAL CODES (Not Part of Part Number): AL=Aluminum BB=Brass CC=Ceramic CM=Chrome-Moly D=Acetal EPDM=Ethylene Propylene Diene Monomer FPM=Fluorocarbon HT=Hi-Temp (EPDM Alternative) NBR=Medium Nitrile (Buna-N) NY=Nylon PVDF=Polyvinylidene Fluoride RTP=Reinforced Composite

S=304SS SCP=304SS/Chrome Plated SNG=Special Blend (Buna) ST4=Special PTFE 4 STL=Steel STCP=Steel/Chrome Plated STZP=Steel/Zinc Plated SZZ=304SS/Zamak TNM=Special High Strength

Center raised pilot guide on the **Adapter Plate** assures proper alignment of pump and engine. Before mounting pump onto engine inspect engine for **recessed seal and bearing guide** to permit adapter to completely seat into recess and four bosses to be flush with engine face.

## 7500S UNLOADER SPECIFICATIONS

SPECIFICATIONS	U.S.	Metric
Flow Range	0.5 - 6.0 gpm	1.89 - 23 lpm
Pressure Range	100 - 2000 psi	6.9 - 138 bar
Inlet Port - Rear	3/8" NPT(M)	3/8" NPT(M)
Discharge Port - Front	3/8" NPT(M)	3/8" NPT(M)
By-Pass Port - Bottom	3/8" NPT(F)	3/8" NPT(F)
Weight	14.4 oz.	0.41 kg
Dimensions	3.0 x 1.0 x 4.25"	76.2 x 25.4 x 108 mm

## PARTS LIST

ITEM	P/N	MATL	DESCRIPTION	QTY
401	32088	NY	Handle, Black	1
402	540081	BB	Cap, Hex Adjusting	1
403	31047	BB	Nut, Lock	1
408	32094	STZP R	Spring, Pressure	1
410	107672	BB	Retainer, Spring	1
412	45694	S	Stem, Piston (M5)	1
414	—	PTFE	Back-up-Ring, Piston Stem	1
415	—	NBR	O-Ring, Piston Stem - 70D	1
425	107673	BB	Retainer, Piston	1
428	—	NBR	O-Ring, Piston Retainer - 70D	1
429	—	NBR	O-Ring, Body	1
430	—	PTFE	Back-up-Ring, Body	1
435	45696	BB	Valve and Ball Assembly (M5)	1
436	107680	S	Seat	1
437	—	NBR	O-Ring, Seat - 70D	1
440	—	BB	Body	1
442	—	NBR	O-Ring, By-Pass Fitting - 70D	1
443	—	BB	Valve, Check w/NBR O-Ring	1
—	—	SS	Valve, Check w/(FPM on EPDM)	1
444	—	S	Spring, Check valve	1
446	—	NBR	O-Ring, Discharge Fitting - 70D	1
455	45695	BB	Fitting, By-Pass [3/8" NPT(F)]	1
460	107681	BB	Fitting, Discharge [3/8" NPT(M)]	1
465	7090	BB	By-Pass Hose (15" x 3/8") (Not Shown)	1
466	7090.40	BB	By-Pass Hose w/Thermo Valve (Not Shown)	1
468	32097	NBR	Kit, O-Ring (Incls: 414, 415, 428, 429, 430, 437, 442, 446) <b>Standard, .3000</b>	1
—	31627	FPM	Kit, O-Ring (Incls: 414, 415, 428, 429, 430, 437, 442, 446) <b>.0110</b>	1
◆	31959	EPDM	Kit, O-Ring (Incls: 414, 415, 428, 429, 430, 437, 442, 446) <b>.0220</b>	1
471	76511	NBR	Kit, Check Valve (Incls: 443, 444, 446,) <b>Standard, .3000</b>	1
—	76516	FPM	Kit, Check Valve (Incls: 443, 444, 446,) <b>.0110</b>	1
◆	76519	EPDM	Kit, Check Valve (Incls: 443, 444, 446,) <b>.0220</b>	1

*Italics are optional items.* R Components comply with RoHS Directive.

◆ Silicone Oil /Grease Required. MATERIAL CODES (Not Part of Part Number):

BB=Brass EPDM=Ethylene Propylene Diene Monomer FPM=Fluorocarbon

NBR=Medium Nitrile (Buna-N) NY=Nylon PTFE=Pure Polytetrafluoroethylene S=304SS

SS=316SS STZP=Steel/Zinc Plated

## EXPLODED VIEW

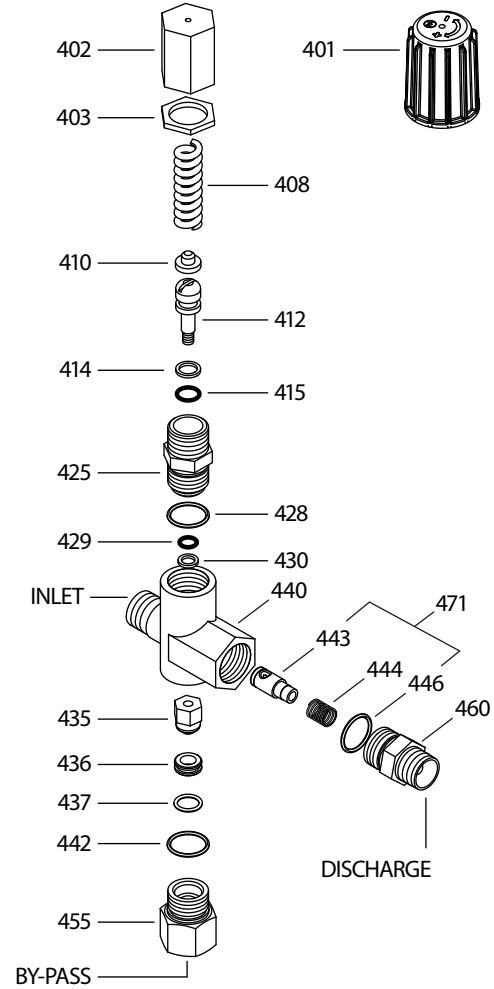

Refer to 7500S Data Sheet for repair procedures and additional technical information.

NOTE: By removing the check valve and spring, this unloader can function as a regulator.

## 7192, 7193, 7194 ADJUSTABLE CHEMICAL INJECTORS SPECIFICATIONS

		U.S.	Metric
Flow Range	7192	2 - 4 gpm	7.6 - 15 lpm
	7193	3 - 5 gpm	11.4 - 19 lpm
	7194	5 - 6 gpm	11.4 - 23 lpm
Orifice Size	7192	1.8 mm	1.8 mm
	7193	2.1 mm	2.1 mm
	7194	2.3 mm	2.3 mm
Max. Pressure		3500 psi	241 bar
Max. Temperature		195° F	90° C
Inlet Port		M18 x 1.0	M18 x 1.0
Discharge Port		3/8" NPT(M)	3/8" NPT(M)
Hose Barb		1/4"	1/4"
Weight		6.3 oz.	0.18 kg
Dimensions		2.0 x 1.0 x 3.0"	50.8 x 25.4 x 76.2 mm

## EXPLODED VIEW

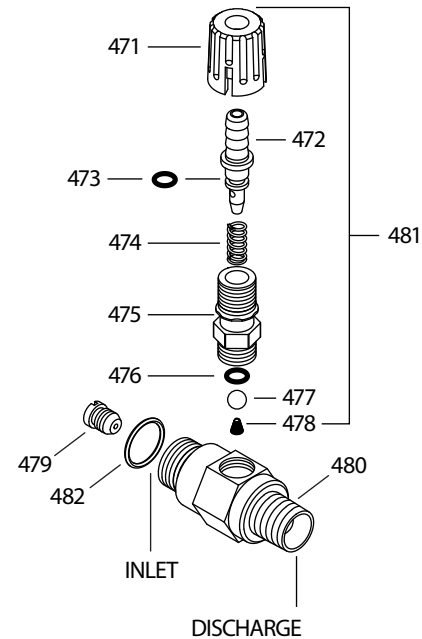

## PARTS LIST

ITEM	P/N	MATL	DESCRIPTION	MODEL USED	QTY
471	33949	NY	Handle, Adjustment	All	1
472	32941	BB	Barb, Adjustable	All	1
473	—	NBR	O-Ring, Hose Barb	All	1
474	33500	S	Spring, Retainer	All	1
475	33946	BB	Retainer, Ball/Seat	All	1
476	33504	FPM	O-Ring, Retainer	All	1
477	34620	SS	Ball, Seat 1/4"	All	1
478	33501	SS	Spring, Ball	All	1
479	32372	S	Injector Orifice (1.8 mm)	7192	1
	32373	S	Injector Orifice (2.1 mm)	7193	1
	32374	S	Injector Orifice (2.3 mm)	7194	1
480	—	BB	Body	All	1
481	33481	BBNY	Barb Assy, Adjustable (Incls: 471,472,473,474,475,476,477,478)	All	1
482	13969	NBR	O-Ring, Body - 70D	All	1

*Italics are optional items.*

Material Codes (Not Part of Part No.): BB=Brass FPM=Fluorocarbon  
NBR=Medium Nitrile (Buna-N) NY=Nylon S=304SS SS=316SS

## CAUTION

Deduct the pressure drop shown in the performance chart from your desired system pressure to arrive at the maximum high pressure nozzle rating. This is essential to avoid over-pressurizing the pump.

## EXAMPLE

$$\left[ \begin{array}{l} \text{System - 4 GPM, 2000 PSI} \\ \text{Injector - 7193} \\ \text{Pressure Drop - 250 PSI} \end{array} \right] = \left[ \begin{array}{l} \text{Low Pressure Nozzle - 375 PSI} \\ \text{Max. High Pressure Nozzle - 1750 PSI} \end{array} \right]$$

Flush system after chemical application to prevent clogging and to prolong life.

## PERFORMANCE CHART

Model	Desired Flow	Orifice Size (mm)	Low PSI Nozzle (max. injecting pressure less hose friction loss)	Max. Chemical Draw (oz/min)	Pressure Drop across orifice (deduct from Hi-Pressure)
7192	2 gpm	1.8	225 psi	60	150
7192	3 gpm	1.8	275 psi	60	300
7192	4 gpm	1.8	450 psi	60	500
7193	3 gpm	2.1	225 psi	54	150
7193	4 gpm	2.1	375 psi	54	250
7193	5 gpm	2.1	600 psi	54	400
7194	3 gpm	2.3	150 psi	50	125
7194	4 gpm	2.3	225 psi	50	220

Optimum performance of chemical injector occurs with a 35 ft. high pressure hose and a minimum 3/8 I.D. The type of hose, extended lengths, reduced I.D. and fittings may create back pressure in excess of the low pressure nozzle rating and prevent the injector from drawing chemical. Deduct hose friction loss from the above PSI nozzle. Contact Cat Pumps for assistance with other options.

## TROUBLESHOOTING

No Chemical Draw:

- Low pressure nozzle sized for too high pressure.
- Air leak in suction line.
- Worn injector orifice.

Leaking Around Adjusting Collar:

- O-ring worn.
- Foreign material in injector.

## ELECTRIC MOTOR SPECIFICATIONS (60 hz, 1 hp)

Contact Cat Pumps for additional motor options including the 3 ph, 50 hz, etc...

### Model 8050

Horsepower	1.5
Shaft Diameter	5/8"
Maximum Volts	115/230
Full Load Amps	12.1
RPM	3450
Weight	32.1 lbs.
Phase	Single
Frame Size	56-C TEFC
Service Factor	1.15

### Model 8052

Horsepower	2.0
Shaft Diameter	5/8"
Maximum Volts	115/230
Full Load Amps	17.0/9.2-8.5
RPM	3450
Weight	32.5 lbs.
Phase	Single
Frame Size	56-C TEFC
Service Factor	1.15

### Model 8055

Horsepower	3.0
Shaft Diameter	3/4" **
Maximum Volts	230
Full Load Amps	15.2/13.6
RPM	3450
Weight	46.3 lbs.
Phase	Single
Frame Size	56-C TEFC
Service Factor	1.15

\*\* Use 3/4" shaft size motor with GES Models.

### Model 8057

Horsepower	5.0
Shaft Diameter	3/4" **
Maximum Volts	230
Full Load Amps	22.0
RPM	3450
Weight	40 lbs.
Phase	Single
Frame Size	56-C OPEN DRIP
Service Factor	1.15

\*\* Use 3/4" shaft size motor with GES Models.

### Model 8060\*

Horsepower	1.5
Shaft Diameter	5/8"
Maximum Volts	115/208 - 230
Full Load Amps	13.6/7.5 - 6.8
RPM	1725
Weight	40 lbs.
Phase	Single
Frame Size	56-C TEFC
Service Factor	1.15

\* Use with ELS models or to reduce flow by 50% on standard models.

### Model 8062\*

Horsepower	2.0
Shaft Diameter	5/8"
Maximum Volts	115/230
Full Load Amps	18.8/9.4
RPM	1725
Weight	47 lbs.
Phase	Single
Frame Size	56-HC TEFC
Service Factor	1.15

\* Use with ELS models or to reduce flow by 50% on standard models.

### Models 8125/8125W

Horsepower	2.5	2.2
Shaft Diameter	5/8"	5/8"
Maximum Volts	115/230	110/220
Full Load Amps	20.8/10.4	22/11
RPM	1750	1450
Weight	52.9 lbs.	52.9 lbs.
Phase	Single	Single
Hertz	60	50
Frame Size	56-C TEFC	56-C TEFC
Service Factor	1.15	1.15

### Common Motor Specifications

Max. Ambient Temperature	104° F
Hertz	60 Hz
Capacitor Start	Yes
Thermal Overload-Manual Rest	Yes

Note: Motor Start-Up AMPS may vary, then settle within FULL LOAD AMPS rating after initial run in time.

Before mounting pump on motor, apply P.N. 6106 Antiseize Lubricant to pump shaft.

Refer to Tech Bulletin 055 for instructions on removing pump from gas engine or electric motor.

## MOTOR DIMENSIONS

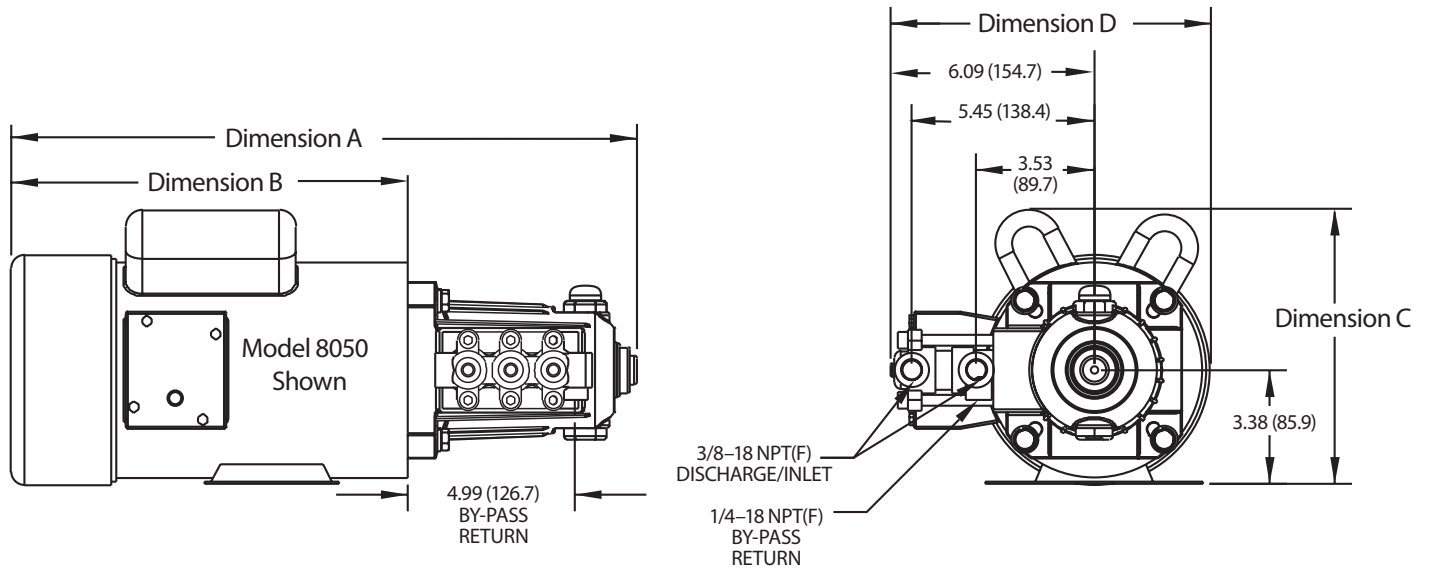

MODEL	8050	8052	8055	8057	8060	8062	8125
Dimension A	18.2	18.2	20.0	18.7	18.8	19.7	19.1
Dimension B	11.3	11.3	13.1	11.8	11.9	12.8	12.2
Dimension C	8.4	8.4	8.3	9.0	8.9	8.9	9.6
Dimension D	9.5	9.5	9.5	9.5	9.7	9.7	9.7

**DETERMINING THE REQUIRED H.P.**      Hp (Electric Brake)      =       $\frac{\text{gpm} \times \text{psi}}{1460}$

For proper gas or diesel engine selection consult your engine supplier

## ELECTRIC HORSEPOWER REQUIREMENTS

FLOW		PRESSURE					PUMP RPM
		psi 700	psi 1000	psi 1200	psi 1500	psi 2000	
gpm	lpm	bar 48	bar 69	bar 83	bar 103	bar 138	
1.0	3.8	.48	.68	.82	1.0	1.4	3450
2.2	8.3	1.1	1.5	1.8	2.3	3.0	1725/3450
2.85	10.8	1.36	2.0	2.3	2.9	N/A	1725
3.0	11.4	1.4	2.1	2.5	3.1	4.1	3450
3.5	13.2	1.67	2.39	2.87	3.59	N/A	3450

## UNLOADER TYPE

Each pump comes with a pressure sensitive regulating unloader. This unloader will set system pressure. While in by-pass the line pressure will drop to a low pressure mode and then quickly build up to set system pressure when the system is back to full use.

## INSTALLATION AND START-UP

Install a pressure gauge close to the manifold head of the pump to assist in setting system pressure and to periodically monitor system pressure. By-pass line can be directed to the ground, or to a reservoir or be redirected to the 1/4" NPT(F) port on bottom side of inlet manifold. If routing to pump inlet use a 3/8" flexible hose and thermo valve.

**NOTE:** If not using a thermo valve **DO NOT EXCEED 6 MINUTES** in by-pass.

**NOTE:** For Hi-Temp seal pumps **DO NOT USE THERMO VALVE**, use optional dual pressure switches and mechanical relays.

Pump should be purged of air before commencing with operation. Liquid must flow through the pump without discharge restriction to assure full system pressure is reached.

Setting and adjusting the unloader pressure must be done with the system turned on. Start the system with the unloader backed off to the lowest pressure setting (counterclockwise direction). Squeeze the trigger and read the pressure on the gauge at the pump. Do not read pressure at the gun or nozzle. If more pressure is desired, release the trigger, turn adjusting cap one quarter turn in a clockwise direction. Squeeze the trigger and read the pressure. Repeat this process until the desired system pressure is reached. Thread locking nut up to adjusting cap.

**NOTE:** Pressure is not set at the factory.

## SERVICE

The unloader should be serviced on the same schedule as the seals in the pump. Refer to SF Plunger Pump Service Manual for start-up, servicing of seals and valves, torque requirements and diagnosis and maintenance chart.

### **⚠ CAUTIONS AND WARNINGS**

All High Pressure Systems require a primary pressure regulating device (i.e. regulator, unloader) and a secondary pressure relief device (i.e. pop-off valve, relief valve). Failure to install such relief devices could result in personal injury or damage to pump or property. Cat Pumps does not assume any liability or responsibility for the operation of a customer's high pressure system.

Read all CAUTIONS and WARNINGS before commencing service or operation of any high pressure system. The CAUTIONS and WARNINGS are included in each service manual and with each Accessory Data sheet. CAUTIONS and WARNINGS can also be viewed online at [www.catpumps.com/cautions-warnings](http://www.catpumps.com/cautions-warnings) or can be requested directly from Cat Pumps.

### **WARRANTY**

View the Limited Warranty on-line at [www.catpumps.com/warranty](http://www.catpumps.com/warranty).