

DATA SHEET

35 FRAME PLUNGER PUMP

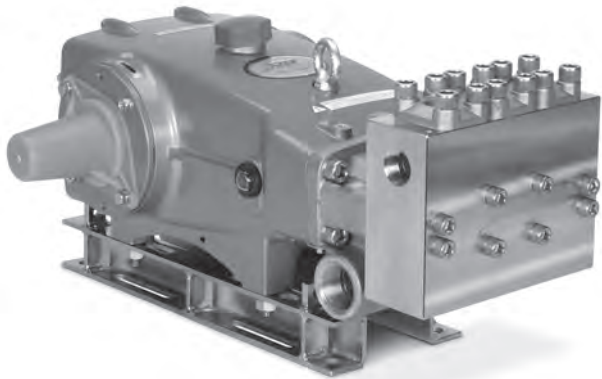

Model: 3560



Model 3560 Shown
(Shaft protector included, mounting rails sold separately)

FEATURES

- Triplex design delivers high efficiency and low pulsation.
- Durable dual V-Packings are lubricated and cooled by pumped liquid.
- Pre-set Lo-Pressure Seals provide secondary protection against external leaks and require no packing adjustment.
- Special high-density, polished, concentric plungers provide a true wear surface and extended seal life.
- Wet-end easily serviced without entering crankcase.
- Standard NBR seals with alternative options for temperature and chemical compatibility.

SPECIFICATIONS

	U.S. Measure	Metric Measure
Flow	20 gpm	76 lpm
Pressure Range	100-4000 psi	6.9-275 bar
Pump RPM*	1160 rpm	1160 rpm
Inlet Pressure Range	Flooded to 70 psi	Flooded to 4.8 bar
Max. Liquid Temp. (NBR)	160° F	71° C

Alternative seals available for high temperature up to 190°F

Bore	0.984"	25 mm
Stroke	1.890"	48 mm
Crankcase Capacity	4.2 qts	4 L
Inlets Ports (2)	1 1/2" NPT(F)	1 1/2" NPT(F)
Discharge Ports (2)	1" NPT(F)	1" NPT(F)
Pulley Mounting	Either Side	Either Side
Shaft Diameter	1.378"	35 mm
Weight	142 lbs	64.4 kg
Dimensions	23.54 x 18.11 x 9.88"	598 x 460 x 251 mm

*Pump minimum is 100 RPM.

ALTERNATE SPECIFICATIONS

	U.S. Measure	Metric Measure
Flow	25 gpm	95 lpm
Pressure Range	100-3000 psi	6.9-210 bar
Pump RPM *	1450 rpm	1450 rpm

ALTERNATIVE SEAL CONFIGURATION

MATERIAL	SUFFIX CODE	MAXIMUM TEMPERATURE	
NBR	—	160° F	(71° C)
FPM	.0110	180° F	(82° C)
STHT	.3400	190° F	(88° C)

See Reference Document 99REF017 for inlet conditions and RPM at high temperature.

$$\text{DETERMINING THE PUMP R.P.M.} \quad \frac{\text{Rated gpm}}{\text{Rated rpm}} = \frac{\text{"Desired" gpm}}{\text{"Desired" rpm}}$$

$$\text{DETERMINING THE REQUIRED H.P.} \quad \frac{\text{Hp (Electric Brake)}}{1460} = \frac{\text{gpm x psi}}{1460}$$

$$\text{DETERMINING MOTOR PULLEY SIZE} \quad \frac{\text{Motor Pulley O.D.}}{\text{Pump rpm}} = \frac{\text{Pump Pulley O.D.}}{\text{Motor rpm}}$$

Refer to pump **Service Manual** for repair procedure and additional technical information.

PARTS LIST

ITEM	P/N	MATL	DESCRIPTION	QTY
2	34021	STL	Key (M10x8x70)	1
5	96049	S	Screw, HHC, Sems (M10x25) (See Tech Bulletin 125) [06/18]	8
8	134604	ALE	Cover, Bearing (See Tech Bulletin 118, 125) [06/18]	2
9	815279	FBR	Shim, Split, 2-Pc (See Tech Bulletin 125) [06/18]	2
10	12398	NBR	O-Ring, Bearing Cover - 70D	2
11	13296	NBR	Seal, Oil, Crankshaft	2
15	29326	STL	Bearing, Roller	2
20	121467	TNM	Rod, Connecting Assy (Incls: 21, 22, 23)	3
21	126749	STCP R	Washer, Locking (M10)	3
22	126593	STCP R	Washer, Flat (M10)	6
23	122045	STZP	Screw, HH (M10x55)	6
25	29325	FCM	Crankshaft, Dual End (M 48)	1
31	828710	PE	Protector, Oil Cap w/ Foam Gasket	1
32	43211	ABS	Cap, Oil Filler	1
33	14177	NBR	O-Ring, Oil Filler Cap - 70D	1
34	126743	STCP R	Bolt, Eye (M12x1.75) (For Lifting Pump Only)	1
37	92241	—	Gauge, Oil, Bubble w/Gasket	2
38	44428	NBR	Gasket, Flat, Oil Gauge - 80D	2
40	125753	S	Screw, HHC, Sems (M8x25)	8
48	25625	STCP	Plug, Drain (1/4"x19BSP)	1
49	23170	NBR	O-Ring, Drain Plug - 70D	1
50	45936	ALE	Cover, Crankcase (See Tech Bulletin 118)	1
51	16612	NBR	O-Ring, Crankcase - 70D	1
53	134786	ALE	Crankcase Assy (Incls: 34, 54) (08/10) (See Tech Bulletin 118, 125) [06/18]	1
54	27488	S	Pins, Guide	2
56	27790	POP	Pan, Oil	1
59	92538	S	Screw, HHC, Sems (M6x16)	2
64	43864	CM	Pin, Crosshead	3
65	49076	SSHB	Rod, Plunger	3
69	126587	STCP R	Washer, Oil Seal	3
70	100488	NBR S	Seal, Oil, Crankcase	3
75	110669	S	Slinger, Barrier	3
88	110670	S	Washer, Keyhole (M16)	3
90	48535	CC	Plunger (M25x110)	3
95	126549	STCP R	Stud, Plunger Retainer (M7x103)	3
96	20184	PTFE	Back-up-Ring, Plunger Retainer	3
97	14190	NBR	O-Ring, Plunger Retainer - 70D	3
	14161	FPM	O-Ring, Plunger Retainer - 70D	3
98	44069	SS	Gasket, Retainer	3
99	44068	SS	Retainer, Plunger (M7)	3
100	855017	—	Retainer, Seal 2-Pc (See Tech Bulletin 105)	3
101	44096	—	Wick, Long Tab	3
106	44086	NBR	Seal, LPS w/SS-Spg	3
	45846	FPM	Seal, LPS w/SS-Spg	3
	76086	ST2	Seal, LPS w/S	3
110	49759	FBB	Manifold, Inlet (08/10)	1
112	11379	NBR	O-Ring, Inlet Manifold - 70D	3
	14183	FPM	O-Ring, Inlet Manifold	3
117	44585	S	Screw, HSH (M14x40)	4
126	48538	BB	Adapter, Female	3
127	44610	STG	V-Packing	6
128	48539	BB	Adapter, Male	3
155	17629	NBR	O-Ring, Spacer V/P - 80D	6
	14183	FPM	O-Ring, Spacer V/P	6
156	28243	PTFE	Back-up-Ring, Spacer V/P	6
157	49082	BB	Spacer, V/P	3
160	49092	NBR	O-Ring, Seat, Inlet - 80D	3
	49155	FPM	O-Ring, Seat, Inlet - 70D	3
161	49091	S	Seat, Inlet	3
162	49088	PTFE	Back-up-Ring, Discharge Seat	3
163	49087	NBR	O-Ring, Seat, Discharge - 70D	3
	49154	FPM	O-Ring, Seat, Discharge - 70D	3
164	49086	S	Seat, Discharge	3
165	49090	PVDF	Retainer, Spring, Inlet	3
166	49089	S	Valve	6
167	44109	SS	Spring	6
168	49085	PVDF	Retainer, Spring, Discharge	3
172	18690	NBR	O-Ring, Valve Plug - 70D	3
	11744	FPM	O-Ring, Valve Plug	3
173	20369	PTFE	Back-up-Ring, Valve Plug	3
174	49093	BB	Plug, Valve	3

EXPLODED VIEW

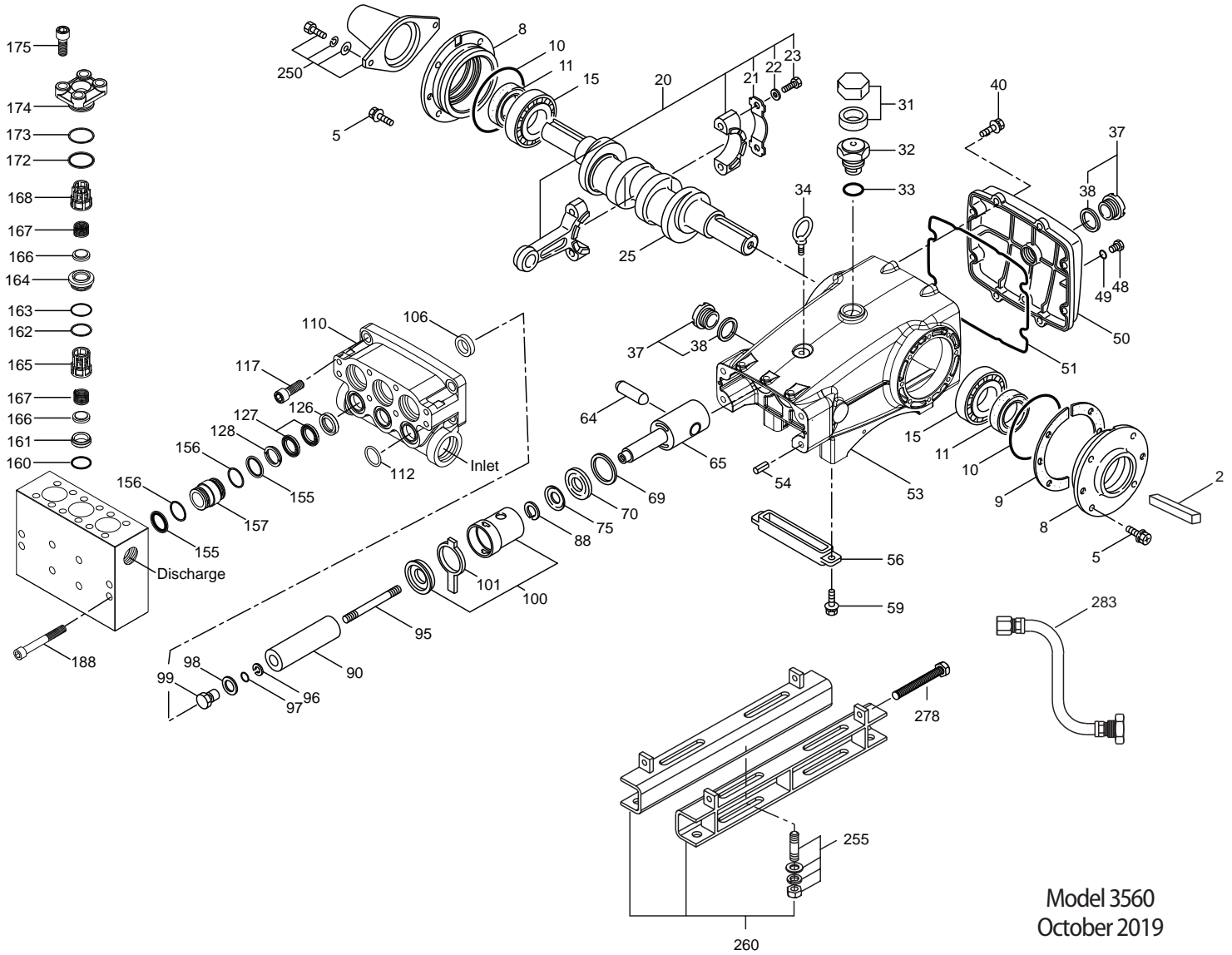

Model 3560
October 2019

ITEM	P/N	MATL	DESCRIPTION	QTY
175	550176	S	Screw, HSH (M14x35)	12
185	49084	SS	Manifold, Discharge	1
188	49045	S	Screw, HSH (M12x95)	8
250	855042	NY	Protector, Shaft w2 Screws, Lockwashers and Washers (Included with Pump) (See Tech Bulletin 125)	1
255	34018	STZPR	Kit, Direct Mount	1
260	92674	STZP	Mounting, Box Assy (Incls: 34018)	1
275	990013	STL	Hub, B, 35mm, w/Keyway (See Tech Bulletin 003)	1
278	80540	ZP	Screw, HH (M12x100) (Rail Adjusting Screw)	2
283	34334	—	Kit, Oil Drain (3/8" x 24") (See individual Data Sheet)	1
290	6124	—	Gasket, Liquid (3 oz.)	1
299	816958	BBSS	Complete Head w/NBR Seals and O-Rings	1
300	31280	NBR*	Kit, Seal (Incls: 97, 106, 112, 127, 155, 156) Standard	1
	31380	FPM*	Kit, Seal (Incls: 97, 106, 112, 127, 155, 156) .0110	1
	76376	STHT	Kit, Seal (Incls: 97, 106, 112, 127, 155, 156) .3400	1
310	31292	NBR	Kit, Valve (Incls: 160, 161, 162, 163, 164, 165, 166, 167, 168, 172, 173) Standard, .3400	1
	31296	FPM	Kit, Valve (Incls: 160, 161, 162, 163, 164, 165, 166, 167, 168, 172, 173) .0110	1
—	819000	F	Assy, Crankcase, Cast Iron Conversion	1
—	6100	—	Oil, Case (12 Bottles) ISO 68 Hydraulic (Fill to specified crankcase capacity prior to start-up)	1

Italics are optional items. * Review material codes for individual items (STG generally may be used as alternate). R Components comply with RoHS Directive.

[] Date of latest production change View Tech Bulletins 035, 074, 083, 105, 118 and 125 for additional information.

MATERIAL CODES (Not Part of Part Number): ABS=ABS Plastic ALE=Aluminum Epoxy BB=Brass BBSS=Brass/316SS CC=Ceramic
 CM=Chrome-Moly F=Cast Iron FBB=Forged Brass FBR=Fiber FCM=Forged Chrome-Moly FPM=Fluorocarbon NBR=Medium Nitrile (Buna-N)
 NBRS=Buna, Silicone Free NY=Nylon PE=Polyethylene POP=Polypropylene PTFE=Pure Polytetrafluoroethylene PVDF=Polyvinylidene Fluoride
 S=304SS SS=316SSSHB=316SS/High Strength STCP=Steel/Chrome Plated STG=Special Blend PTFE White STHT=Special PTFE High Temp
 STL=Steel STZP=Steel/Zinc Plated TNM=Special High Strength ZP=Zinc Plated

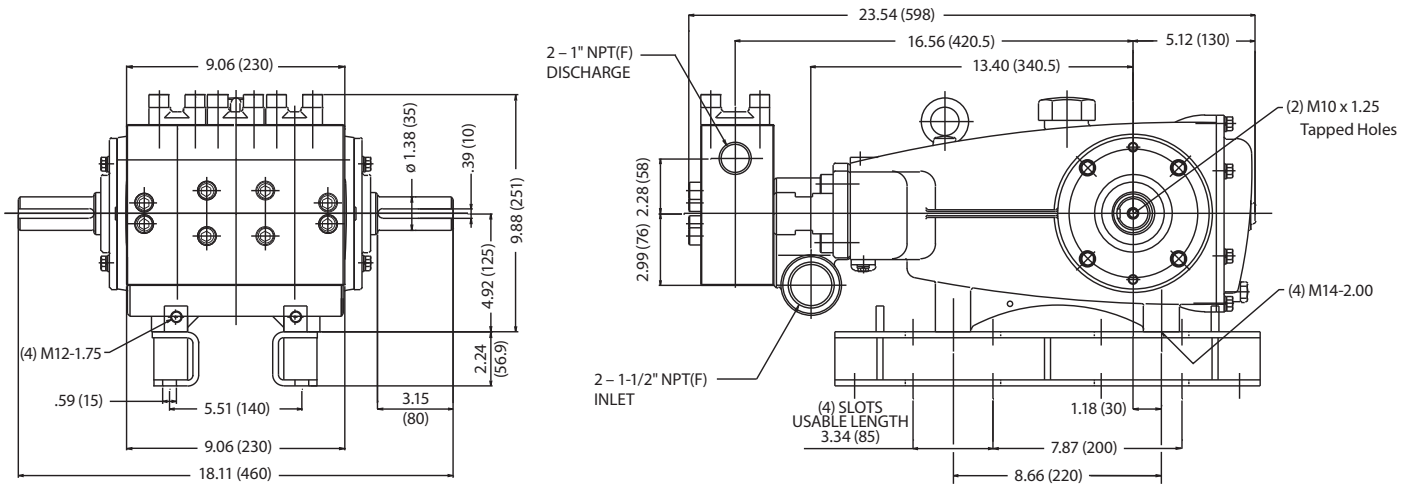

⚠ CAUTIONS AND WARNINGS

All High Pressure Systems require a primary pressure regulating device (i.e. regulator, unloader) and a secondary pressure relief device (i.e. pop-off valve, relief valve). Failure to install such relief devices could result in personal injury or damage to pump or property. Cat Pumps does not assume any liability or responsibility for the operation of a customer's high pressure system.

Read all CAUTIONS and WARNINGS before commencing service or operation of any high pressure system. The CAUTIONS and WARNINGS are included in each service manual and with each Accessory Data sheet. CAUTIONS and WARNINGS can also be viewed online at www.catpumps.com/cautions-warnings or can be requested directly from Cat Pumps.

WARRANTY

View the Limited Warranty on-line at www.catpumps.com/warranty.