

DATA SHEET

DIRECT-DRIVE PLUNGER PUMPS

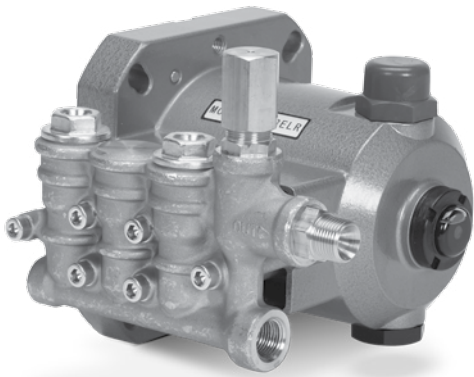

Electric Model: 4DX03ELR



Model 4DX03ELR Shown

FEATURES

- Fits standard 56C face motors.
- Dual plunger design provides a smooth liquid flow.
- Specially formulated Hi-Pressure Seals and concentric solid ceramic plungers assure true wear surface and extended seal life.
- Stacked stainless steel valve design for long life and easy servicing.
- Compact, direct-drive unit for maximum portability.
- Integral pressure regulator with built-in by-pass standard on all units to assure system pressure control and pump protection.
- Includes crankcase oil.

SPECIFICATIONS

	U.S. Measure	Metric Measure
Flow	0.3 gpm	1.14 lpm
Max. Discharge Pressure	2000 psi	138 bar
RPM	1750 rpm	1750 rpm
Inlet Pressure Range	Flooded to 60 psi	Flooded to 4 bar
Bore	0.630"	16 mm
Stroke	0.078"	2.0 mm
Crankcase Capacity	8.5 oz.	0.25 l
Max Liquid Temperature	140° F	60° C
Above 130°F call Cat Pumps for inlet conditions and elastomer recommendations.		
Inlet Port (1)	3/8" NPT(F)	3/8" NPT(F)
Discharge Ports (1)	3/8" NPT(M)	3/8" NPT(M)
Shaft Diameter	5/8"	15.8 mm
Weight	10.7 lbs.	4.9 kg
Dimensions	7.17 x 7.72 x 6.22"	182 x 196 x 158 mm

ELECTRIC HORSEPOWER REQUIREMENTS

MODELS	FLOW		PRESSURE		RPM
			psi 1000	psi 2000	
	U.S. gpm	lpm	bar 69	bar 138	
4DX03ELR	0.3	1.14	0.28	0.56	1750

DETERMINING THE PUMP R.P.M.	Rated gpm	=	"Desired" gpm
	Rated rpm	=	"Desired" rpm
DETERMINING THE REQUIRED H.P.	gpm x psi	=	Electric Brake
	1060	=	H. P. Required

Refer to pump **Service Manual** for repair procedure and additional technical information.

EXPLODED VIEW

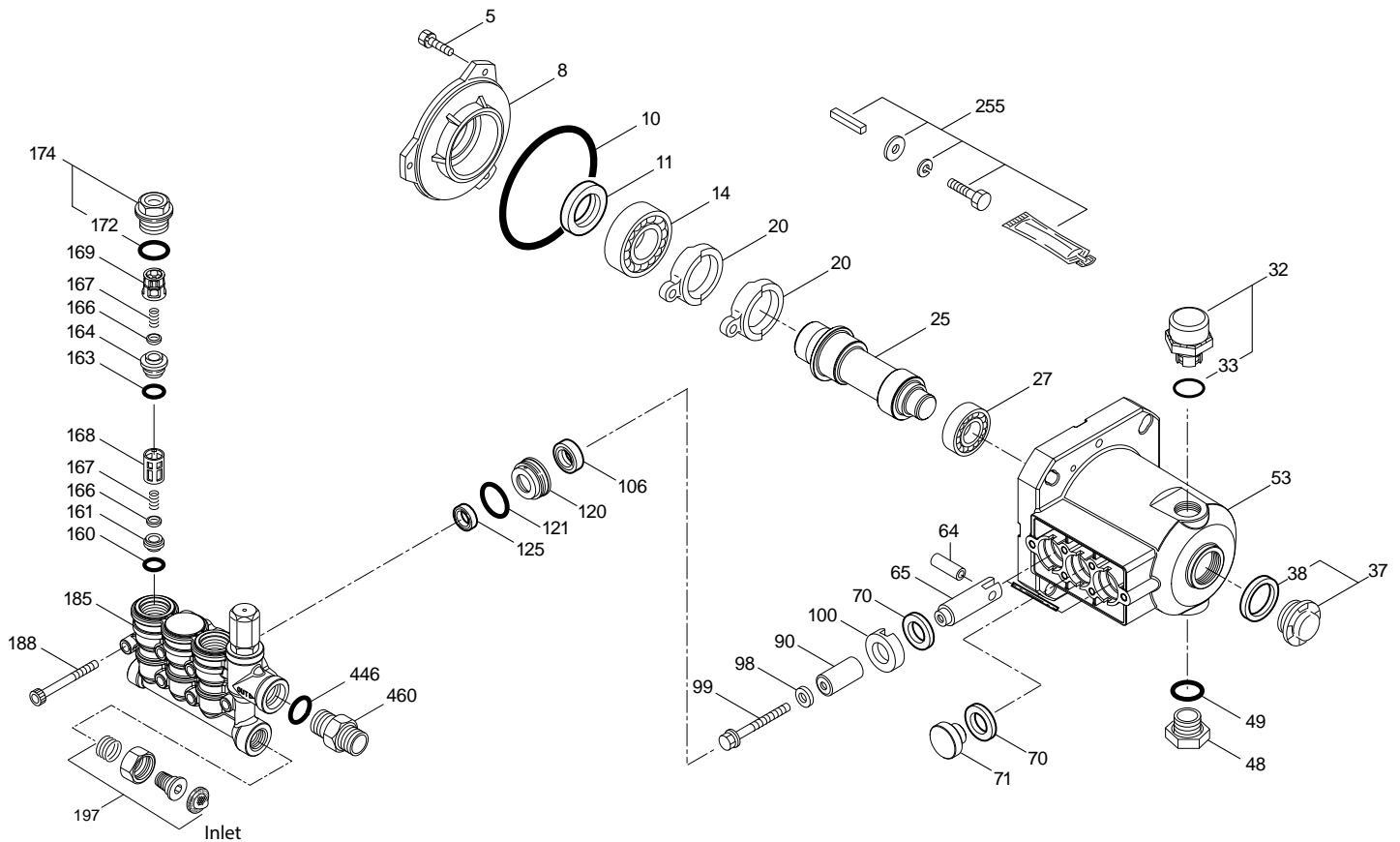

PARTS LIST

ITEM	P/N	MATL	DESCRIPTION	QTY	ITEM	P/N	MATL	DESCRIPTION	QTY
5	549360	STCP R	Screw, HH (M6x14)	3	106	† 48222	NBR	Seal, LPS w/S-Spg - 85D	2
8	547153	AL	Cover, Bearing	1	120	547357	BB	Case, Seal	2
10	14041	NBR	O-Ring, Bearing Cover - 70D	1	121	13976	NBR	O-Ring, Seal Case - 70D	2
11	55337	NBR	Seal, Oil - 70D	1	125	46240	NBR	Seal, HPS w/S	2
15	14488	STL	Bearing, Ball - Inner	1	160	13965	NBR	O-Ring, Seat, Inlet - 70D	2
20	547048	TNM	Rod, Connecting	2	161	545177	S	Seat, Inlet	2
25	133148	CM	Crankshaft, 1750 RPM, 5/8", 2.0 mm	1	163	19285	NBR	O-Ring, Seat, Discharge - 70D	2
27	15710	STL	Bearing, Ball - Outer	1	164	545178	S	Seat, Discharge	2
32	549726	—	Cap, Vented w/O-Ring (Rain Cap)	1	166	46764	S	Valve	4
33	14179	NBR	O-Ring, Oil Filler Cap - 70D	1	167	46865	S	Spring	4
37	92241	—	Gauge, Bubble Oil w/Gasket	1	168	543988	PVDF	Retainer, Spring, Inlet	2
38	44428	NBR	Gasket, Flat Flex, Oil Gauge - 80D	1	169	49764	PVDF	Retainer, Spring, Discharge	2
48	44842	NY	Plug, Drain	1	172	142807	NBR	O-Ring, Plug - 90D	2
49	14179	NBR	O-Ring, Drain Plug - 70D	1	174	547104	BB	Plug, Valve (M20x1.5) w/O-Ring	2
53	49801	AL	Crankcase	1	185	133149	BB	Head, Manifold w/Integral Regulator Body	1
64	46229	CM	Pin, Crosshead	2	188	549357	STCP R	Screw, HSH (M6x60)	6
65	132190	BB	Rod, Plunger	2	197	941516	BB	Assy, GH, 3/8" FNPT	1
70	47215	NBR	Seal, Oil - 70D	3	255	30516	STZP R	Assy, Bolt Mount	1
71	133150	BB	Retainer, Oil Seal	1	300	76054	NBR	Kit, Seal (Incls: 98, 106, 121, 125)	1
90	542403	CC	Plunger (M16x27)	2	310	77032	NBR	Kit, Valve	1
98	46730	NBR	Washer, Seal - 90D	2				(Incls: 160, 161, 163, 164, 165, 166, 167, 168, 172)	
99	542405	S	Retainer, Plunger (M6x35)	2	400	—	—	Regulator, Integral (See Individual Parts)	1
100	46233	D	Retainer, Seal	2	460	107681	BB	Fitting, Discharge [3/8" NPT(M)]	1

Italics are optional items.

R Components comply with RoHS Directive. † Production parts are different than repair parts.

See Tech Bulletins 002, 024, 036, 043, 055, 074, 083, 086 and 094 for additional information.

MATERIAL CODES (Not Part of Part Number): AL=Aluminum BB=Brass CC=Ceramic CM=Chrome-moly D=Acetal NBR=Medium Nitrile (Buna-N) NY=Nylon PVDF=Polyvinylidene Fluoride RTP=Reinforced Composite S=304SS STL=Steel STCP=Steel/Chrome Plated STZP=Steel/Zinc Plated TNM=Special High Strength

NOTE: Discard Key which may come standard with most motors and **use only the key included in this kit.**

Note: Pump is shipped with two black caps w/o-rings for shipping purposes.
Remove black cap w/o-ring on top of pump and replace with loose red cap w/o-rings as supplied in box.

INTEGRAL REGULATOR

SPECIFICATIONS	U.S.	Metric
Flow	0.3 gpm	1.14 lpm
PSI Range	100 - 2000 psi	6.9 - 138 bar
Inlet Port	3/8" NPT(F)	3/8" NPT(F)
Discharge Port	3/8" NPT(M)	3/8" NPT(M)

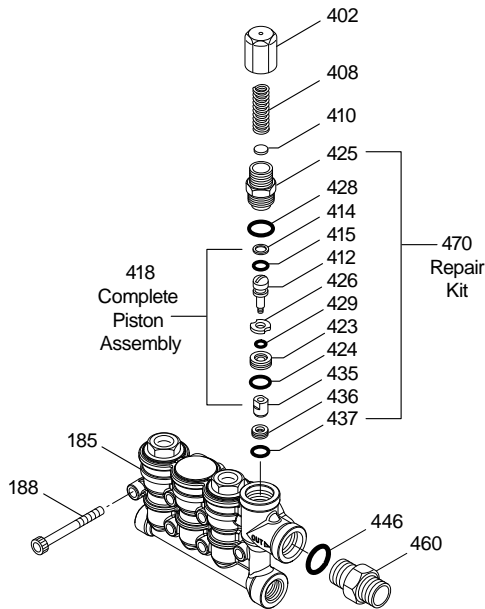

PARTS LIST

ITEM	PN	MATL	DESCRIPTION	QTY
401	32088	NY	Handle, Adjustable (Not Shown)	1
402	46570	BB	Cap, Adjusting	1
408	33394	STZP R	Spring, Pressure	1
410	549352	STCP R	Retainer, Spring	1
412	46251	BB	Stem, Piston	1
414	28338	PTFE	Back-up-Ring, Piston Stem	1
415	22056	NBR	O-Ring, Piston Stem - 70D	1
418	—	—	Assy, Piston Included In Repair Kit	1
423	46249	BB	Retainer, Valve	1
424	13966	NBR	O-Ring, Valve Retainer (Outer) - 70D	1
425	46248	BB	Retainer, Piston	1
426	46250	S	Washer	1
428	26133	NBR	O-Ring, Piston Retainer - 80D	1
429	17399	NBR	O-Ring, Valve Retainer (Inner) - 80D	1
435	548193	S	Valve	1
436	46253	S	Seat	1
437	13963	NBR	O-Ring, Seat - 70D	1
446	26133	NBR	O-Ring, Body - 80D	1
460	107681	BB	Fitting, Discharge 3/8" NPT(M)	1
468	76754	NBR	Kit, O-Ring (Incls: 414,415,424,428,429,437)	1
470	76031	NBR	Kit, Repair (Incls: 418,425,428,436,437)	1

Italics are optional items. R Components comply with RoHS Directive.

MATERIAL CODES (Not Part of Part Number): BB=Brass NBR=Medium Nitrile (Buna-N)

NY=Nylon PTFE=Pure Polytetrafluoroethylene S=304SS

STCP=Steel/Chrome Plated STZP=Steel/Zinc Plated

INSTALLATION

An integral Regulator with built-in by-pass is part of the discharge manifold to provide system pressure regulation and pump protection.

OPERATION

Pump should be purged of air before commencing with operation. Liquid must flow through the pump without discharge restriction to assure full system pressure is reached. Install a pressure gauge close to the manifold head of the pump to assist in setting system pressure and to periodically monitor system pressure. Setting and adjusting the regulator pressure must be done with the system turned on. Start the system with the regulator backed off to the lowest pressure setting (counterclockwise direction). Squeeze the trigger and read the pressure on the gauge at the pump. Do not read pressure at the gun or nozzle. If more pressure is desired, release the trigger, turn adjusting cap one quarter turn in a clockwise direction. Squeeze the trigger and read the pressure. Repeat this process until the desired system pressure is reached. **NOTE:** Pressure is not set at the factory.

SERVICE

The regulator should be serviced on the same schedule as the seals in the pump.

1. Remove hex adjusting cap, spring and spring setainer.
 2. Using a socket or wrench, remove piston retainer from the regulator body.
NOTE: Loctite® 242® is used in the assembly process.
 3. Using a needle nose pliers, pull the complete piston assembly from the regulator body.
 4. Using caution, grasp the valve with a pliers near the top next to the valve retainer and unthread the piston stem using a flat head screwdriver.
 5. Remove o-rings from valve retainer, and back-up-ring and o-ring from piston stem. Examine o-rings and back-up-ring for cuts or wear and replace as needed.
 6. Examine the valve, valve retainer and piston stem for wear and replace as needed.
NOTE: The seat will be damaged during removal and must be replaced.
 7. Replace seat and stem from repair kit.
 8. Lubricate all o-rings for ease of installation.
 9. Press complete piston assembly into chamber with valve facing down.
 10. Apply Loctite® 242® to threads of piston retainer with o-ring. Thread into body and tighten using a wrench.
 11. Insert spring retainer and spring into the body.
 12. Thread the adjusting cap into the body and set for system pressure.
- NOTE:** If unit is infrequently used or periodically stored, o-rings may become dry and will need to be replaced.

NOTE: This pump has an internally by-passed Regulator and if the pump is operated with no flow out the nozzles (100% by-pass), heat damage will occur to the seals and valve retainers in a short period of time.

Loctite and 242 are registered trademarks of the Henkel Corporation.

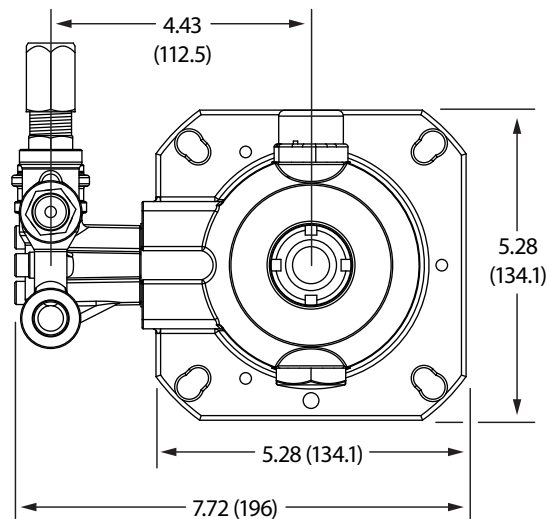
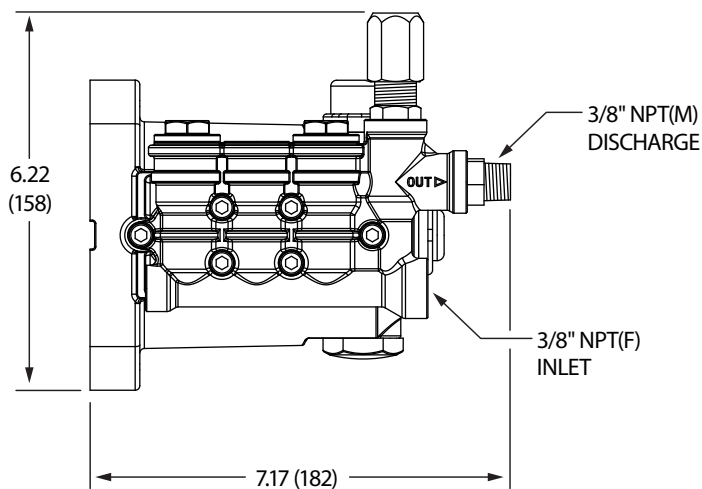

Model 4DX03ELR

⚠ CAUTIONS AND WARNINGS

All High Pressure Systems require a primary pressure regulating device (i.e. regulator, unloader) and a secondary pressure relief device (i.e. pop-off valve, relief valve). Failure to install such relief devices could result in personal injury or damage to pump or property. Cat Pumps does not assume any liability or responsibility for the operation of a customer's high pressure system.

Read all CAUTIONS and WARNINGS before commencing service or operation of any high pressure system. The CAUTIONS and WARNINGS are included in each service manual and with each Accessory Data sheet. CAUTIONS and WARNINGS can also be viewed online at www.catpumps.com/cautions-warnings or can be requested directly from Cat Pumps.

WARRANTY

View the Limited Warranty on-line at www.catpumps.com/warranty.



CAT PUMPS
 1681 - 94TH LANE N.E. MINNEAPOLIS, MN 55449-4324
 PHONE (763) 780-5440 — FAX (763) 780-2958
 e-mail: techsupport@catpumps.com
www.catpumps.com