

DATA SHEET

5CP PLUNGER PUMPS



The Pumps with Nine Lives

Brass Model: 5CP6120

Gearbox Model: 5CP6120CSSG1



Model 5CP6120 Shown
(Rails and shaft protector sold separately)

FEATURES

- Industrial high performance design offers reliability and versatility.
- Ultra-compact footprint enhances direct-drive pump-motor unit with bell housing and flexible coupling mount.
- Optional direct-drive motor and gearbox requirements.
- Press-in seal cases and interchangeable valve assemblies for easy servicing.
- Standard NBR seals with alternative options for temperature and chemical compatibility.
 - FPM – .0110
 - EPDM – .0220
 - High Temp, 190° F – .3000
 - High Temp, 200° F – .3400 (Intermittent Run Dry)

COMMON

SPECIFICATIONS

	U.S.	Metric
Inlet Pressure Range	Flooded to 60 psi	Flooded to 4.1 bar
Max. Liquid Temperature	160° F	71° C
Above 130°F call Cat Pumps for inlet conditions and elastomer recommendations.		
Crankcase Capacity	17 oz.	0.51 l
Inlet Ports (2)	1/2" NPT(F)	1/2" NPT(F)
Discharge Ports (2)	3/8" NPT(F)	3/8" NPT(F)
Shaft Diameter	0.787"	20 mm
Dimensions (Pump Only)	11.01 x 10.00 x 5.82"	279 x 254 x 148 mm
Dimensions (w/ Gearbox)	11.01 x 12.40 x 6.38"	279 x 315 x 162 mm

SPECIFICATIONS

	U.S. Measure	Metric Measure
5CP6120		
Flow	6.0 gpm	23 lpm
Pressure Range	100 to 1600 psi	6.9 to 110 bar
Pump RPM*	1400 rpm	1400 rpm
Bore	0.787"	20 mm
Stroke	0.709"	18 mm
Weight	19.9 lbs.	9 kg
5CP6120CSSG1		
Flow	6.7 gpm	25 lpm
Pressure Range	100 to 1600 psi	6.9 to 110 bar
Pump RPM	1570 rpm	1570 rpm
Engine RPM	3200 rpm	320 rpm
Weight	26.5 lbs.	12 kg

ALTERNATE SPECIFICATIONS

	U.S. Measure	Metric Measure
5CP6120		
Flow	7.4 gpm	28 lpm
Pressure Range	100 to 1200 psi	6.9 to 85 bar
Pump RPM*	1725 rpm	1725 rpm

*Pump minimum is 100 RPM

ELECTRIC HORSEPOWER REQUIREMENTS

MODELS	FLOW		PRESSURE				RPM
			psi	psi	psi	psi	
			900	1200	1450	1600	
	gpm	lpm	bar	bar	bar	bar	
			62	83	100	110	
5CP6120	6.0	23	3.7	4.9	6.0	6.6	1400
5CP6120ALT	7.4	28	4.6	6.1	N/A	N/A	1725
5CP6120CSSGI	6.7	25	Consult Engine Manufacturer				1570

DETERMINING THE PUMP R.P.M.

$$\frac{\text{Rated gpm}}{\text{Rated rpm}} = \frac{\text{"Desired" gpm}}{\text{"Desired" rpm}}$$

DETERMINING THE REQUIRED H.P.

$$\frac{\text{Hp (Electric Brake)}}{1460} = \frac{\text{gpm x psi}}{1460}$$

DETERMINING MOTOR PULLEY SIZE

$$\frac{\text{Motor Pulley O.D.}}{\text{Pump rpm}} = \frac{\text{Pump Pulley O.D.}}{\text{Motor rpm}}$$

See complete Drive Packages [Includes: pulleys, belts, hubs, key] Tech Bulletin 003.
Refer to pump **Service Manual** for repair procedure and additional technical information.

PARTS LIST

ITEM	PART NUMBERS	MATL	DESCRIPTION	QTY
	5CP6120			
	5CP6120CSSG1			
2	30057	STL	Key (M6x6x25)	1
5	126542	STCPR	Screw, HHC, Sems (M8x16)	8
8	46910	AL	Cover, Bearing	2 - 1
10	14028	NBR	O-Ring, Bearing Cover - 70D	2 - 1
11	43222	NBR	Seal, Oil, Crankshaft - 70D	2 - 0
15	14480	STL	Bearing, Ball	2
20	48742	TNM	Rod, Connecting Assy [10/01]	3
25	46928	FCM	Crankshaft, Dual End M18 - 5CP6120	1
	48233	FCM	Crankshaft, Single End M18 - 5CP6120CSSG1	1
30	49776	AL	Cover, Bearing - 5CP6120CSSG1	1
31	127409	—	Cap, Vented w/O-Ring (Rain Cap)	1
32	46798	—	Cap, Oil Filler, Domed	1
33	14179	NBR	O-Ring, Oil Filler Cap - 70D	1
37	92241	—	Gauge, Oil, Bubble w/Gasket - 80D	1 - 2
38	44428	NBR	Gasket, Flat, Oil Gauge - 80D	1 - 2
40	125824	STCPR	Screw, HHC, Sems (M6x16)	4
48	25625	STCP	Plug, Drain (1/4"x19BSP)	1
49	23170	NBR	O-Ring, Drain Plug - 70D	1
50	46940	AL	Cover, Rear	1
51	14044	NBR	O-Ring, Rear Cover	1
53	48617	AL	Crankcase	1
64	46746	CM	Pin, Crosshead	3
65	48458	BBNP	Rod, Plunger	3
70	46838	NBR	Seal, Oil, Crankcase - 70D	3
75	43328	S	Slinger, Barrier	3
88	45697	S	Washer, Keyhole (M18x10)	3
90	46841	CC	Plunger (M20x50)	3
98	46730	NBR	Washer, Seal - 90D	3
	48394	FPM	Washer, Seal - 90D	3
	◆ 48432	EPDM	Washer, Seal	3
99	† 48201	SS	Retainer, Plunger w/Stud (M6)	3
100	46749	PVDF	Retainer, Seal	3
106	43305	NBR	Seal, LPS w/S-Spg	3
	45153	FPM	Seal, LPS w/SS-Spg	3
	76305	ST2	Seal, LPS w/S-Spg	3
120	46843	BB	Case, Seal	3
	49436	BB	Case, Seal (Model 5CP6120.3400 Only) (Use w/76305,13978)	3
121	13978	NBR	O-Ring, Seal Case-70D	3
	14329	FPM	O-Ring, Seal Case	3
	◆ 48904	EPDM	O-Ring, Seal Case	3
125	43307	SNG	Seal, HPS w/S	3
	44936	FPM	Seal, HPS w/S	3
	46667	HT	Seal, HPS, 2-Pc w/S-Support	3
139	22179	BBCP	Plug, Inlet [1/2"NPT(M)]	1
162	43248	PTFE	Back-up-Ring, Seat	6
163	43249	NBR	O-Ring, Seat - 80D	6
	44383	FPM	O-Ring, Seat - 70D	6
	◆ 46206	EPDM	O-Ring, Seat - 70D	6
164	43722	S	Seat	6
166	43721	S	Valve	6
167	43751	S	Spring	6
168	44564	PVDF	Retainer, Spring	6
172	17617	NBR	O-Ring, Valve Plug -90D	6
	11691	FPM	O-Ring, Valve Plug - 90D	6
	◆ 46207	EPDM	O-Ring, Valve Plug -70D	6
174	125214	BBCP	Plug, Valve	6
185	49761	BBCP	Manifold, Head	1
188	126513	STCPR	Screw, HSH (M8x70)	8
196	22187	BBCP	Plug, Discharge [3/8"NPT(M)]	1
250	118672	STCP	Protector, Shaft (Model 5CP6120 only)	1
255	30243	STZP	Mount, Direct	1
260	30611	STZPR	Mount, Rail, Assy	1
	30637	STZP	Mount, Angle Assy-Retro Fit (See Tech Bulletin 078)	1
265	30659	—	Kit, Complete Mounting (Incls: 30611, 30633, 118672) (Model 5CP6120 only)	1
275	30944	STL	Assembly, Hub & Key (Incls. 30945, 30057)	1

EXPLODED VIEW

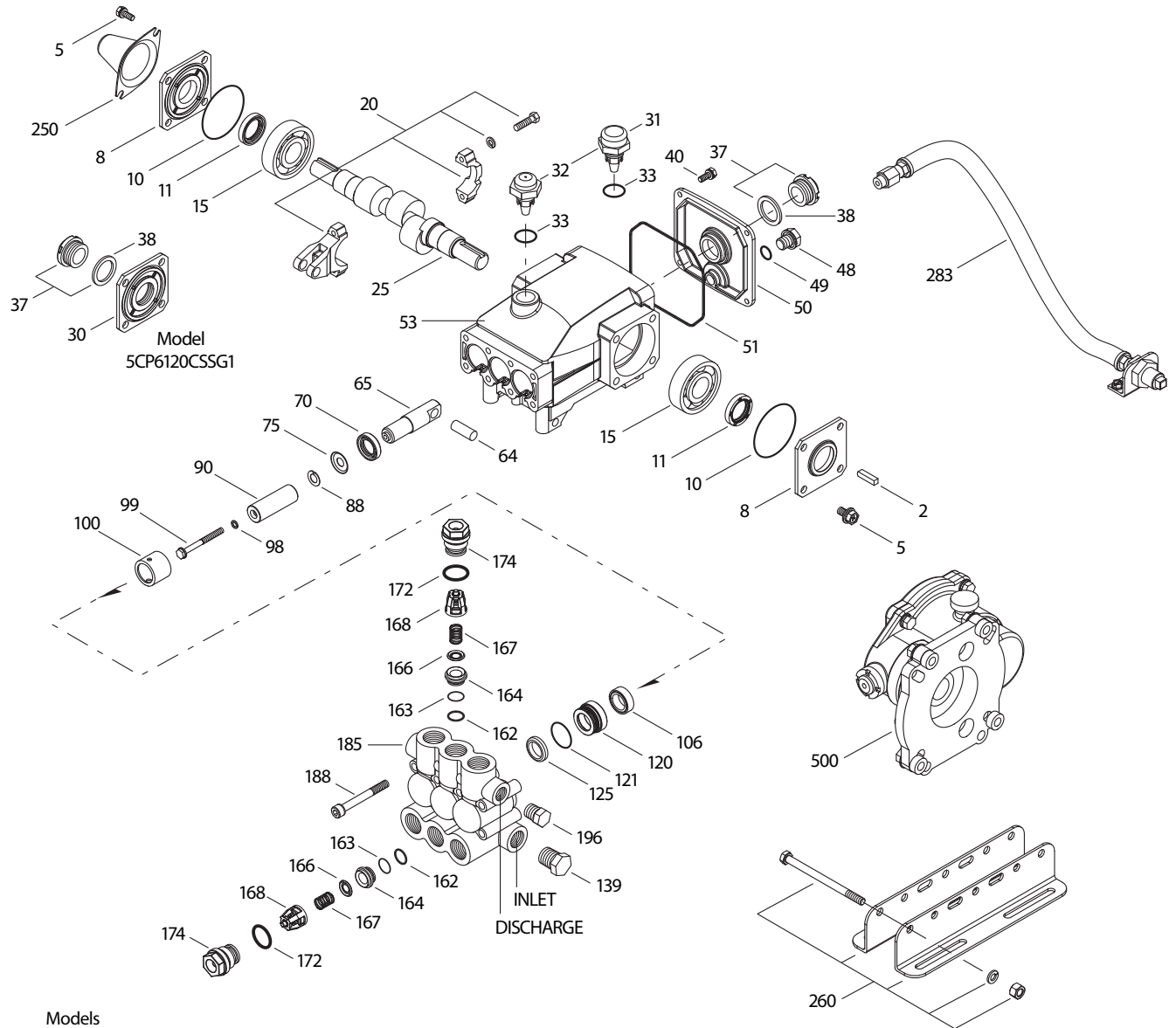

Models
SCP6120, SCP6120CSSG1
April 2017

ITEM	PART NUMBERS	DESCRIPTION	QTY
	SCP6120	MATL	
	SCP6120CSSG1		
283	34334	Kit, Oil Drain (3/8" x 24") (See Individual Data Sheet)	1
	76334	Kit, Oil Indicator (3/8" x 24") (See Individual Data Sheet)	1
299	816666	BBCP Head, Complete w/NBR Seals & O-Rings	1
300	33628	NBR Kit, Seal (Incls: 98,106,121,125) Standard	1
	31628	FPM Kit, Seal (Incls: 98,106,121,125) .0110	1
◆	31648	EPDM Kit, Seal (Incls: 98,106,121,125) .0220	1
	31638	HT Kit, Seal (Incls: 98,106,121,125) .3000	1
	76536	STHT Kit, Seal (Incls: 98,106,120,121,125) .3400	1
310	30820	NBR Kit, Valve Preassembled (Incls: 162,163,164,166-168,172) Standard, .3000, .3400	2
	31263	FPM Kit, Valve Preassembled (Incls: 162,163,164,166-168,172) .0110	2
◆	31259	EPDM Kit, Valve Preassembled (Incls: 162,163,164,166-168,172) .0220	2
350	30696	STZP Pliers, Reverse	1
500	8076	Gearbox (See Individual Data Sheet)	1
—	6107	Oil, Bottle (21 oz.) ISO 68 Hydraulic (Fill to specified crankcase capacity prior to start-up)	1

Bold print part numbers are unique to a particular pump model. Italics are optional items. [] Date of latest production change.

◆ Silicone oil/grease required. † Production parts are different than repair parts. R Components comply with RoHS Directive.

View Tech Bulletins 002, 003, 024, 036, 043, 053, 060, 061, 064, 073, 074, 078 and 083 for additional information.

MATERIAL CODES (Not Part of Part Number): AL=Aluminum BB=Brass BBCP=Brass/Chrome Plated BBNP=Brass/Nickel Plated CC=Ceramic CM=Chrome-moly

EPDM=Ethylene Propylene Diene Monomer FCM=Forged Chrome-moly FPM=Fluorocarbon HT=Hi-Temp (EPDM Alternative) NBR=Medium Nitrile (Buna-N)

PTFE=Pure Polytetrafluoroethylene PVDF=Polyvinylidene Fluoride S=304SS SS=316SS SNG=Special Blend (Buna) ST2=Special Blend PTFE

STHT=Special PTFE High Temp. STL=Steel STCP=Steel/Chrome Plated STZP=Steel/Zinc Plated TNM=Special High Strength

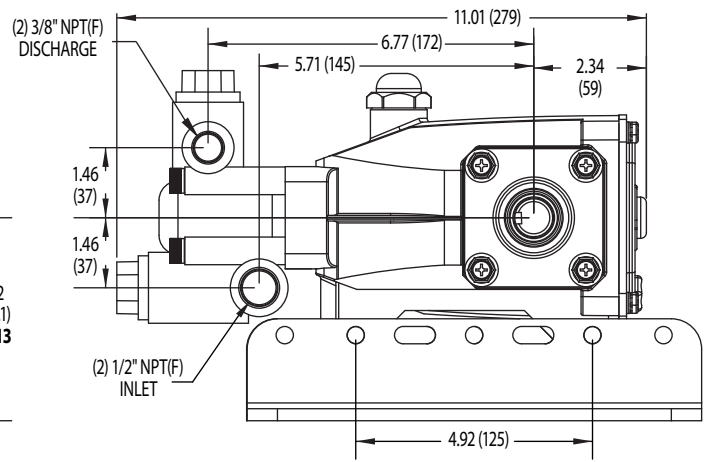
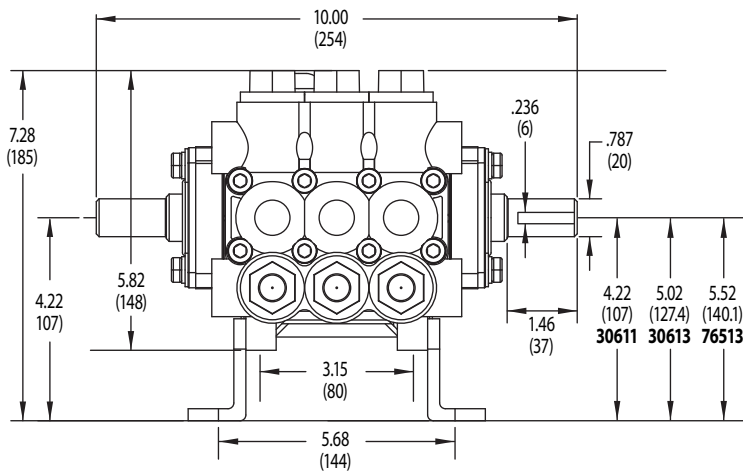

Model 5CP6120

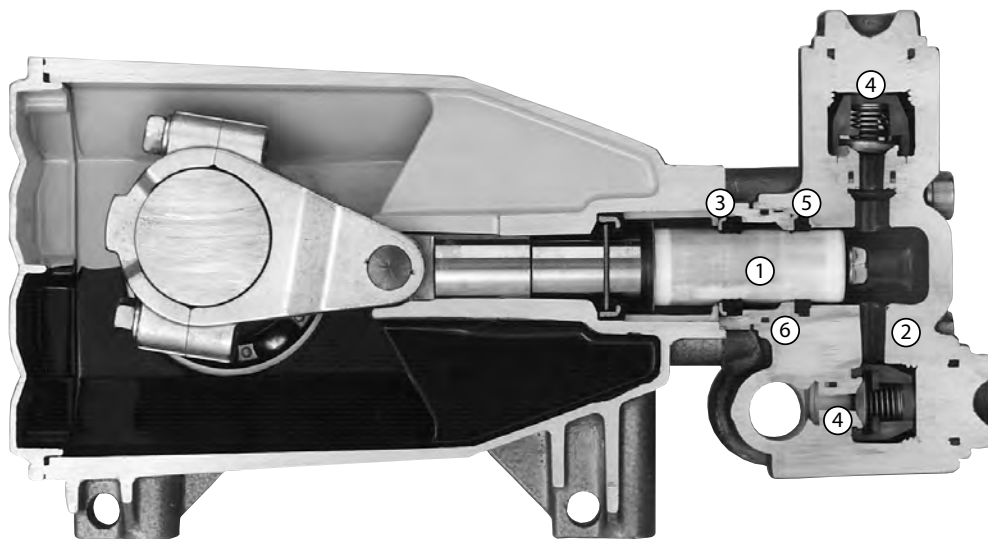

1. Special concentric, high density, polished, solid ceramic plungers provide a true wear surface and extended seal life.
2. Manifolds are a high tensile strength chrome plated forged brass for long term, continuous duty.
3. 100% wet seal design adds to service life by allowing pumped liquids to cool and lubricate on both sides of the seals.
4. Stainless steel valves, seats and springs provide corrosion-resistance, ultimate seating and extended life.
5. Specially formulated, Cat Pump exclusive, Lo-Pressure and Hi-Pressure Seals offer unmatched performance and seal life.
6. Press-in style seal case offers alignment and support for seals and “no tools” servicing.

⚠ CAUTIONS AND WARNINGS

All High Pressure Systems require a primary pressure regulating device (i.e. regulator, unloader) and a secondary pressure relief device (i.e. pop-off valve, relief valve). Failure to install such relief devices could result in personal injury or damage to pump or property. Cat Pumps does not assume any liability or responsibility for the operation of a customer’s high pressure system.

Read all CAUTIONS and WARNINGS before commencing service or operation of any high pressure system. The CAUTIONS and WARNINGS are included in each service manual and with each Accessory Data sheet. CAUTIONS and WARNINGS can also be viewed online at www.catpumps.com/cautions-warnings or can be requested directly from Cat Pumps.

WARRANTY

View the Limited Warranty on-line at www.catpumps.com/warranty.



CAT PUMPS

1681 - 94TH LANE N.E. MINNEAPOLIS, MN 55449-4324
 PHONE (763) 780-5440 — FAX (763) 780-2958
 e-mail: techsupport@catpumps.com
www.catpumps.com