

DATA SHEET

DIRECT DRIVE PLUNGER PUMPS

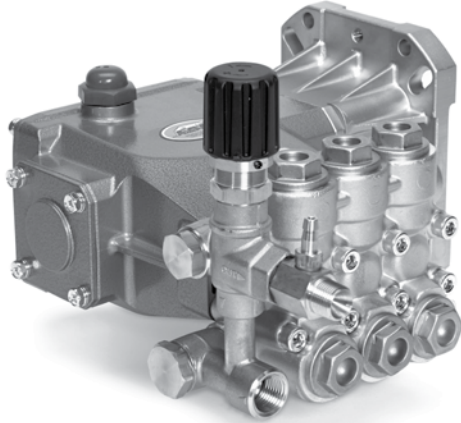

Brass Models: **66DX30G1I, 66DX35G1I, 66DX40G1I**



FEATURES

- Triplex plunger design provides a smooth liquid flow.
- Special concentric, high-density, polished, solid ceramic plungers provide a true wear surface and extended seal life.
- Compact flange mount permits easy, direct mounting to most gas engines.*
- Modular regulating unloader with built-in by-pass is standard for safety and pressure setting.
- Fixed chemical injector is standard and mounts directly onto unloader to provide cleaning flexibility.

*Gas Mounting Flange: SAE J609, Flange B, Extension 4 (1"Ø), Shaft Length= 3 1/4", Pilot Ø= 5 3/4", BC. Ø= 6 1/2", Thread 3/8"-16 UNC Tap.

SPECIFICATIONS	U.S. Measure	Metric Measure
Model 66DX30G1I		
Flow	3.0 gpm	11.4 lpm
Pressure Range	100 to 4000 psi	6.9 - 275 bar
Stroke	0.339"	8.6 mm
Model 66DX35G1I		
Flow	3.5 gpm	13.2 lpm
Pressure Range	100 to 4000 psi	6.9 - 275 bar
Stroke	0.394"	10.0 mm
Model 66DX40G1I		
Flow	4.0 gpm	15.0 lpm
Pressure Range	100 to 4000 psi	6.9 - 275 bar
Stroke	0.449"	11.4 mm

COMMON SPECIFICATIONS

Pump RPM	3400 rpm	3400 rpm
Inlet Pressure Range	Flooded to 75 psi	Flooded to 5.2 bar
Max. Liquid Temperature	140° F	60° C
Bore	0.551"	14 mm
Crankcase Capacity	18.0 oz.	0.55 l
Inlet Ports (2)	1/2" NPT(F)	1/2" NPT(F)
Discharge Ports (2)	3/8" NPT(F)	3/8" NPT(F)
Shaft Diameter (Hollow)	1.0"	25.4 mm
Engine Mounting Face	6.5"	6.5"
Weight	26.15 lbs.	11.9 kg
Dimensions (pump only)	11.73 x 10.51 x 8.15"	298 x 267 x 207 mm

ELECTRIC HORSEPOWER REQUIREMENTS

MODELS	FLOW		PRESSURE			RPM
			psi 2500	psi 3200	psi 4000	
	gpm	lpm	bar 172	bar 220	bar 275	
66DX30G1I	3.0	11.4	5.1	6.6	8.2	3400
66DX35G1I	3.5	13.2	6.0	7.7	9.6	3400
66DX40G1I	4.0	15.0	6.9	8.8	11.0	3400

$$\frac{\text{DETERMINING THE PUMP R.P.M.}}{\text{Rated rpm}} = \frac{\text{Rated gpm}}{\text{"Desired" gpm}}$$

$$\frac{\text{DETERMINING THE REQUIRED H.P.}}{\text{(Electric Brake)}} = \frac{\text{Hp}}{\frac{\text{gpm} \times \text{psi}}{1460}}$$

Refer to pump **Service Manual** for repair procedure and additional technical information.

EXPLODED VIEW

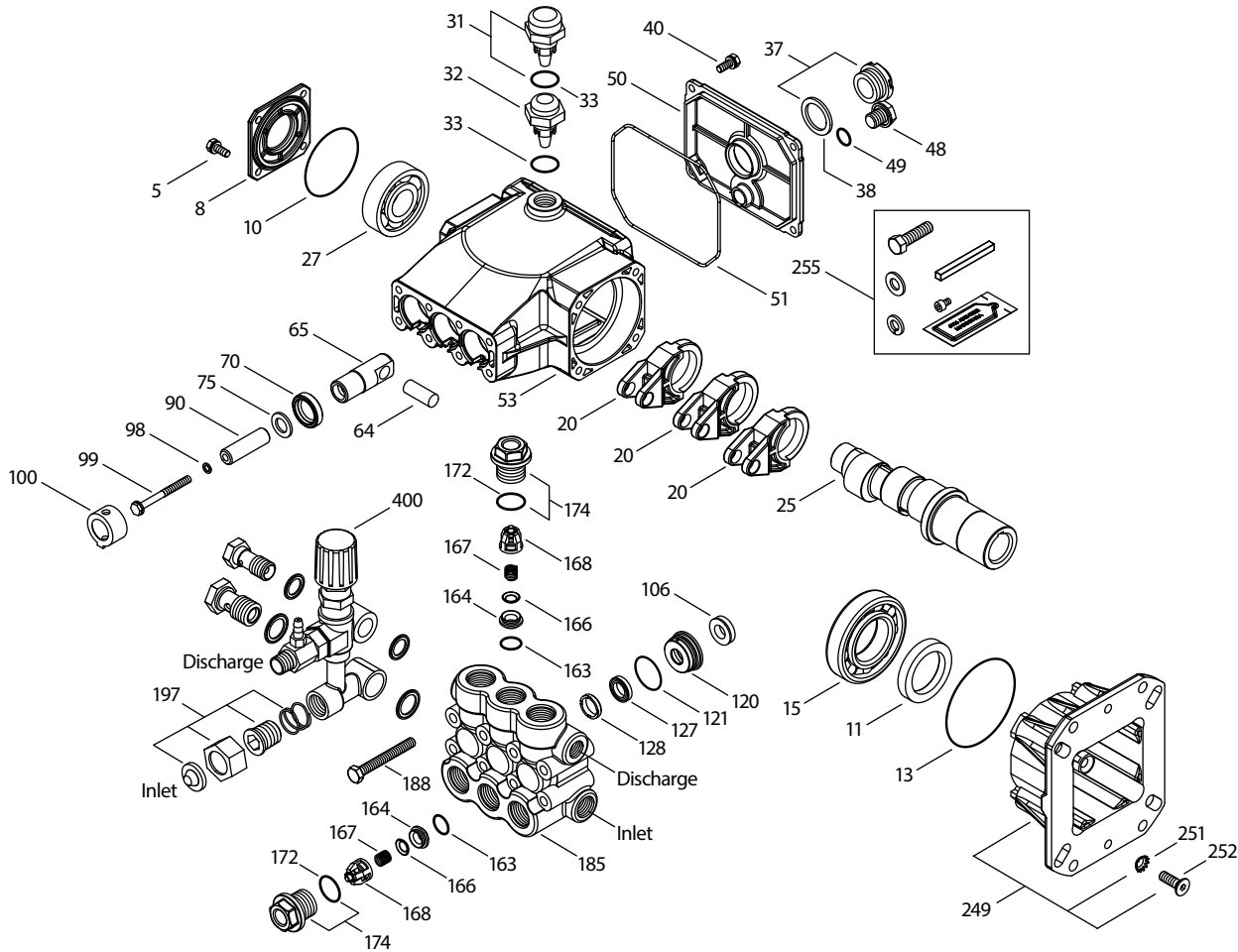

PARTS LIST

ITEM	P/N	MATL	DESCRIPTION	QTY	ITEM	P/N	MATL	DESCRIPTION	QTY
5	125824	STCPR	Screw, HHC (M6x16)	4	98	46730	NBR	Washer Seal, Plunger Retainer - 90D	3
8	48259	AL	Cover, Bearing	1	99	† 48201	SS	Retainer, Plunger	3
10	14028	NBR	O-Ring, Bearing Cover - 70D	1	100	48755	NY	Retainer, Seal	3
11	125351	NBR	Seal, Oil, Crankshaft	1	106	45188	NBR	Seal, LPS w/S-Spg	3
13	14037	NBR	O-Ring, Bearing Cover	1	120	48759	BB	Case, Seal	3
15	146421	STL	Bearing, Ball - Inner	1	121	13980	NBR	O-Ring, Seal Case - 70D	3
20	48843	TNM	Rod, Connecting	3	127	48758	SNG	V-Packing	3
25	48970	CM	Crankshaft (8.6 mm) 30G1l	1		49201	STG	V-Packing	3
	48977	CM	Crankshaft (10.0 mm) 35G1l	1	128	48757	NY	Adapter, Male	3
	48839	CM	Crankshaft (11.4 mm) 40G1l	1	163	17547	NBR	O-Ring, Seat - 85D	6
27	14480	STL	Bearing, Ball - Outer	1	164	45790	S	Seat	6
31	127409	—	Cap, Vented w/ O-Ring (Rain Cap)	1	166	46429	S	Valve	6
32	46798	—	Cap, Domed, Oil Filler	1	167	43750	S	Spring	6
33	14179	NBR	O-Ring, Filler Cap - 70D	1	168	† 44565	PVDF	Retainer, Spring	6
37	92241	—	Gauge, Oil Bubble w/Gasket - 80D	1	172	17616	NBR	O-Ring, Valve Plug - 80D	6
38	44428	NBR	Gasket, Flat, Oil Gauge - 80D	1	174	48760	BB	Plug, Valve w/O-Ring	6
40	125824	STCPR	Screw, HHC (M6x16)	4	185	48846	BB	Head, Manifold	1
48	25625	STCPR	Plug, Drain (1/4"x19BSP)	1	188	126512	STCPR	Screw, HSH (M8x65)	8
49	23170	NBR	O-Ring, Drain Plug - 70D	1	197	941517	BB	Assy, GH 1/2"NPT(F)	1
50	48862	AL	Cover, Rear	1	249	48841	AL	Flange, Adapter	1
51	14048	NBR	O-Ring, Rear Cover	1	251	126746	STCPR	Lockwasher, Conical (M8)	4
53	48830	AL	Crankcase	1	252	46403	STL	Screw, FH (M8x25)	4
64	46404	CM	Pin, Crosshead	3	255	30510	STZP	Assy, Bolt Mount	1
65	48845	BB	Rod, Plunger	3	283	34334	—	Kit, Oil Drain (3/8"x24") (Not Shown)	1
70	48911	NBR	Seal, Oil, Crankcase	3	300	34262	NBR	Kit, Seal (Incls: 98,106,121,127,128)	1
75	48754	NBR	Slinger, Barrier	3	310	34260	NBR	Kit, Valve (Incls: 163,164,166,167,168,172)	2
90	48752	CC	Plunger (M14x47)	3	400	7860	BB	Unloader Assy w/Fixed Injector (Eff. 04/07)	1

Bold Part Numbers are unique to a particular pump model. Italics are optional items.

R Components comply with RoHS Directive. † Production parts different from service parts. View Tech Bulletins 024, 036, 055, 074, 083, and 101 for additional information.

MATERIAL CODES (Not Part of Part Number): AL=Aluminum BB=Brass CC=Ceramic CM=Chrome-moly NBR=Medium Nitrile (Buna-N) NY=Nylon
 PVDF=Polyvinylidene Fluoride S=304SS SNG=Special Blend (Buna) SS=316SS STCPR=Steel/Chrome Plated STG=Special Blend PTFE White STL=Steel
 STZP=Steel/Zinc Plated TNM=Special High Strength

MODEL 7860 UNLOADER WITH INJECTOR

SPECIFICATIONS

	U.S.	Metric
Flow Range	3.0 - 5.0 gpm	7.6 - 19.0 lpm
PSI Range	700 - 4000 psi	50 - 275 bar
Inlet Port, Side	1/2" NPT(F)	1/2" NPT(F)
Discharge Port, Front	3/8" NPT(M)	3/8" NPT(M)
Weight	35.2 oz.	1.0 kg
Dimensions	4.65 x 170 x 6.75"	118 x 43 x 171 mm

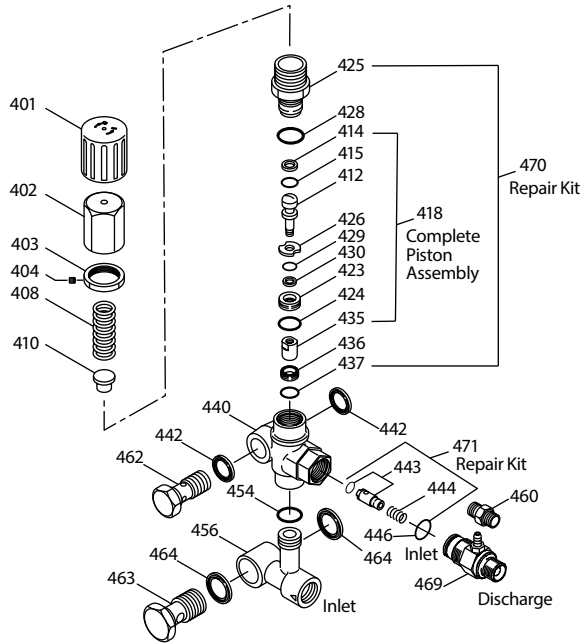

PARTS LIST

ITEM	P/N	MATL	DESCRIPTION	QTY
401	49100	NY	Handle, Adjusting (Black)	1
402	49099	BB	Cap, Adjusting	1
403	125521	BB	Nut, Locking (M25x1)	1
404	88953	S	Screw, Set (M4x4)	1
408	45198	ZP R	Spring, Pressure	1
410	49101	STZP R	Retainer, Spring	1
412	49103	S	Stem, Piston	1
414	129638	PTFE	Back-up-Ring, Piston Stem	1
415	49104	NBR	O-Ring, Piston Stem - 90D	1
418	—	BB	Assy, Piston (Included in Repair Kit)	1
423	49105	BB	Retainer, Valve	1
424	49106	NBR	O-Ring, Valve Retainer - 70D	1
425	49102	BB	Retainer, Piston	1
426	49107	S	Washer	1
428	26133	NBR	O-Ring, Piston Retainer - 80D	1
429	22056	NBR	O-Ring, Valve Retainer - 70D	1
430	49123	D	Back-up-Ring, Valve Retainer	1
435	49383	S	Valve/Ball Assembly	1
436	49384	S	Seat	1
437	13965	NBR	O-Ring, Seat - 70D	1
440	—	BB	Valve Body	1
442	49121	STL	Washer, Seal (3/8")	2
443	49245	BB	Valve, Check w/NBR O-Ring	1
444	117275	S	Spring, Check Valve	1
446	26133	NBR	O-Ring, Body - 80D	1
454	11346	NBR	O-Ring, Manifold - 70D	1
456	—	BB	Manifold	1
460	126974	BB	Fitting, Discharge [3/8" NPT(M)]	1
462	49120	BB	Screw, Flo-Thru [3/8" NPT(M)]	1
463	49117	BB	Screw, Flo-Thru [1/2" NPT(M)]	1
464	49118	STL	Washer, Seal (1/2")	2
468	31708	NBR	Kit, O-Ring (Incls: 414, 415, 424, 428-430, 437, 446, 454)	1
469	7367	BB	Injector, Chemical Fixed	1
470	31556	NBR	Kit, Repair (Incls: 418, 425, 428, 436, 437)	1
471	76185	NBR	Kit, Check Valve (Incls: 443, 444, 446)	1

Italics are optional items. R Components comply with RoHS Directive.

MATERIAL CODES (Not Part of Part Number): BB=Brass D=Acetal
NBR=Medium Nitrile (Buna-N) NY=Nylon PTFE=Pure Polytetrafluoroethylene
S=304SS STL=Steel STZP=Steel/Zinc Plated ZP=Zinc Plated

MODEL 7367 FIXED CHEMICAL INJECTOR

SPECIFICATIONS

	U.S.	Metric
Flow Range	3.0 - 5.0 gpm	11.4 - 19.0 lpm
Nozzle Orifice	2.1 mm	2.1 mm
Hose Barb - Extension	1/4"	1/4"
Tapped Barb	8/32" UNF	8/32" UNF
Inlet Port	M20 x 1"	M20 x 1"
Discharge Port	3/8" NPT(M)	3/8" NPT(M)
Weight	5.3 oz.	0.15 kg
Dimensions	2.0 x 1.0 x 1.75"	52 x 25 x 44 mm

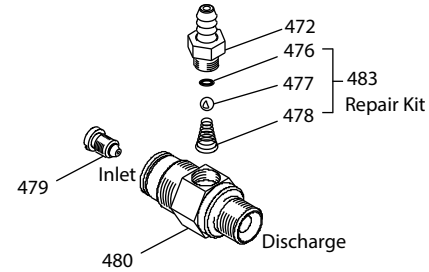

PARTS LIST

ITEM	P/N	MATL	DESCRIPTION	QTY
472	—	BB	Barb	1
476	—	NBR	O-Ring, Barb - 70D	1
477	—	S	Ball	1
478	—	S	Spring	1
479	—	S	Orifice	1
480	—	BB	Body	1
483	76176	NBR	Kit, Repair (Includes: 476, 477, 478)	1

MATERIAL CODES (Not Part of Part Number):
BB=Brass NBR=Medium Nitrile (Buna-N) S=304SS

CHEMICAL INJECTOR PERFORMANCE CHART

Desired Pump Flow	Orifice Size	Maximum Injecting Pressure	Maximum Chemical Draw	Pressure Drop Across Injector At System Pressure (4000 psi)
3.0	2.1 mm	190 psi	70.0 oz/min	136 psi
3.5	2.1 mm	260 psi	74.2 oz/min	245 psi
4.0	2.1 mm	358 psi	76.8 oz/min	288 psi

Optimum performance of chemical injector occurs with a 35 ft. high pressure hose and a minimum 3/8" I.D. The type of hose, extended lengths, reduced I.D. and fittings may create back pressures in excess of the low pressure nozzle rating and prevent the injector from drawing chemical. **Deduct hose friction loss from above low psi nozzle. Contact Cat Pumps for assistance with other options.**

Note: Deduct the pressure drop shown in the performance chart from your desired system pressure to arrive at the maximum high pressure nozzle rating. This is essential to avoid over-pressurizing the pump.

UNLOADER TYPE

A modular regulating unloader with chemical injector comes with each 66DX pump to provide system pressure regulation, pump protection, and metered chemical application.

OPERATION:

Purge pump of air before commencing operation by allowing liquid to flow through the pump without discharge restriction. Removing trapped air will assure full system pressure can be obtained. Install a pressure gauge close to the manifold head of the pump to assist in setting system pressure and to periodically monitor system pressure. Setting and adjusting the unloader pressure must be done with the system turned on. Start the system with the unloader backed off to the lowest pressure setting (counterclockwise direction). Squeeze the trigger and read the pressure on the gauge at the pump. Do not read pressure at the gun or nozzle. If more pressure is desired, release the trigger, turn adjusting cap one quarter turn in a clockwise direction. Squeeze the trigger and read the pressure. Repeat this process until the desired system pressure is reached. Thread locking nut up to adjusting cap and tighten set screw. All high pressure systems should have a secondary relief valve. Set secondary relief valve 200-300 psi above the unloader setting.

NOTE: Pressure is not set at the factory.

SERVICE:

The unloader should be serviced on the same schedule as the seals in the pump. Refer to 66DX Service Manual for start-up, servicing of seals and valves, torque requirements and Diagnosis/Maintenance chart.

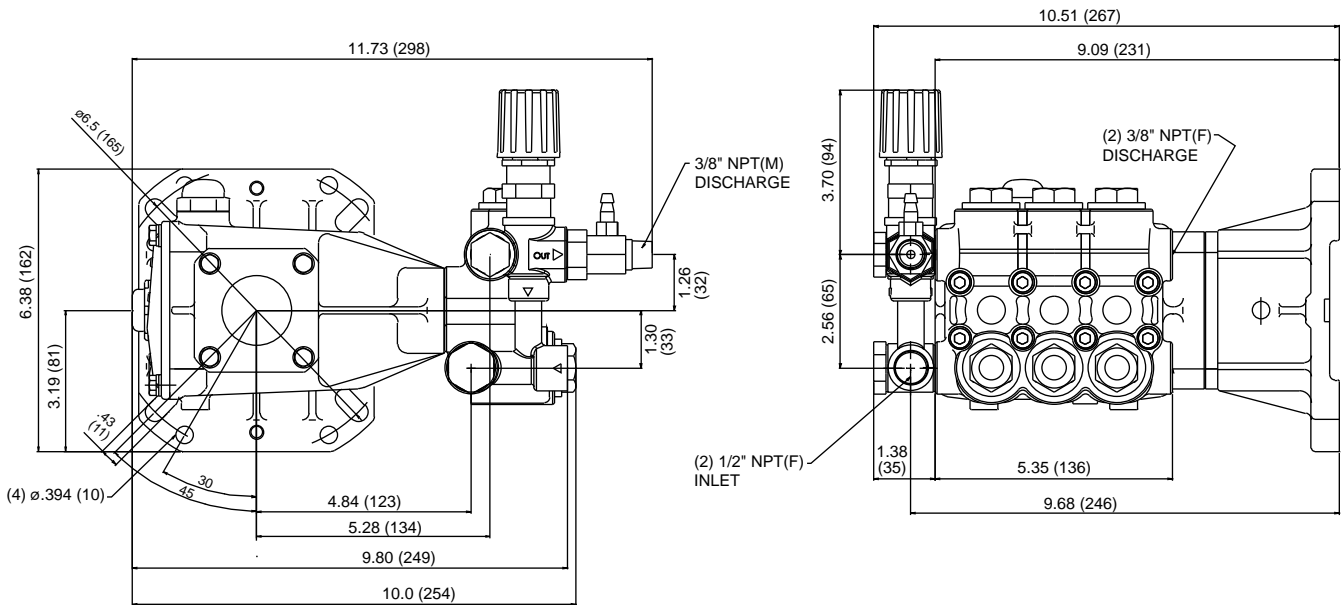

⚠ CAUTIONS AND WARNINGS

All High Pressure Systems require a primary pressure regulating device (i.e. regulator, unloader) and a secondary pressure relief device (i.e. pop-off valve, relief valve). Failure to install such relief devices could result in personal injury or damage to pump or property. Cat Pumps does not assume any liability or responsibility for the operation of a customer's high pressure system.

Read all CAUTIONS and WARNINGS before commencing service or operation of any high pressure system. The CAUTIONS and WARNINGS are included in each service manual and with each Accessory Data sheet. CAUTIONS and WARNINGS can also be viewed online at www.catpumps.com/cautions-warnings or can be requested directly from Cat Pumps.

WARRANTY

View the Limited Warranty on-line at ww.catpumps.com/warranty.



CAT PUMPS

1681 - 94TH LANE N.E. MINNEAPOLIS, MN 55449-4324
 PHONE (763) 780-5440 — FAX (763) 780-2958
 e-mail: techsupport@catpumps.com
www.catpumps.com