

DATA SHEET

60 FRAME PLUNGER PUMP

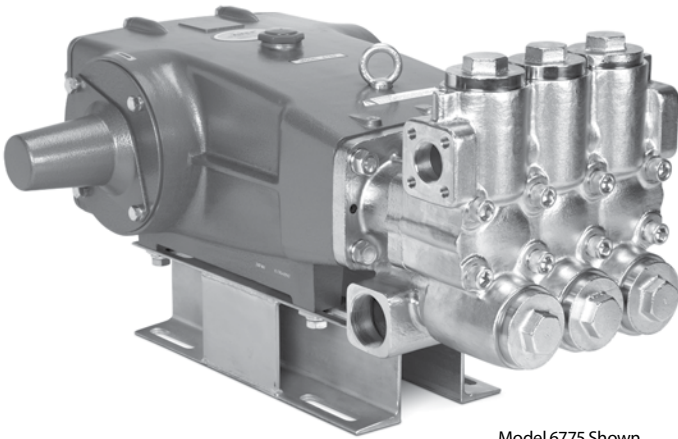

Brass Model: 6775



Model 6775 Shown

SPECIFICATIONS	U.S. Measure	Metric Measure
Flow	75 gpm	284 lpm
Pressure Range	100 to 1200 psi	6.9 to 83 bar
Pump RPM*	650 rpm	650 rpm
Inlet Pressure Range	Flooded to 50 psi	Flooded to 3.5 bar
Max. Liquid Temp. (NBR)	140° F	60° C
Bore	2.165"	55 mm
Stroke	2.579"	65.5 mm
Crankcase Capacity	10 qts.	9.46 l
Inlet Ports (2)	2" NPT(F)	2" NPT(F)
Discharge Ports (2)	1 1/4" NPT(F)	1 1/4" NPT(F)
Shaft Diameter	1.772"	45 mm
Weight	356 lbs.	161 kg
Dimensions	31.14 x 24.37 x 12.87"	791 x 619 x 327 mm

* Pump minimum is 100 RPM.

FEATURES

- Triplex plunger design delivers high efficiency and low pulsation.
- Durable dual V-Packings are lubricated and cooled by pumped liquid.
- Pre-set Lo-Pressure Seals provide secondary protection against external leaks and require no packing adjustment.
- Special high-density, polished, concentric plungers provide a true wear surface and extended seal life.
- Guided valve design for extended valve life.
- Wet-end easily serviced without entering crankcase.
- Standard NBR seals with alternative options for temperature and chemical compatibility.

ALTERNATIVE SEAL CONFIGURATION

MATERIAL	SUFFIX CODE	MAXIMUM TEMPERATURE
NBR	—	140° F (60° C)
FPM	.0110	140° F (60° C)
EPDM	.0220	140° F (60° C)

See Reference Document 99REF017 for inlet conditions and RPM at high temperature.

DETERMINING THE PUMP R.P.M.	Rated gpm	=	"Desired" gpm
	Rated rpm	=	"Desired" rpm
DETERMINING THE REQUIRED H.P.	Hp (Electric Brake)	=	$\frac{\text{gpm} \times \text{psi}}{1460}$
DETERMINING MOTOR PULLEY SIZE	$\frac{\text{Motor Pulley O.D.}}{\text{Pump rpm}}$	=	$\frac{\text{Pump Pulley O.D.}}{\text{Motor rpm}}$

Refer to pump Service Manual for repair procedure and additional technical information.

PARTS LIST

ITEM	PART NUMBER	DESCRIPTION	QTY
5	126532	STCP R Screw, HH (M10 x 40)	8
6	126231	STCP R Lockwasher (M10)	8
7	126574	STZP R Washer, Flat (M10)	8
8	29443	AL Cover, Bearing, Outer (See Tech Bulletin 118)	2
10	29444	NBR O-Ring Outer, Bearing Cover - 70D	2
11	11443	NBR Seal, Oil, Crankshaft - 70D	2
12	126594	STCP R Washer, Shim (M120 x 0.3)	0-2
13	126595	STCP R Washer, Shim (M120 x 0.5)	0-2
15	29441	STL Bearing, Roller	2
16	29442	STL Cover, Bearing, Inner	2
17	29444	NBR O-Ring Inner, Bearing Cover - 70D	2
20	126612	BBHS Rod, Connecting (Includes: 21, 22)	3
21	126560	STCP R Washer, Locking	3
22	126593	STCP R Washer, Shim (M10.5 x 1.5)	6
25	29440	FCM Crankshaft, Dual End (65.5 mm)	1
31	828710	PE Protector, Oil Cap w/Foam Gasket	1
32	43211	ABS Cap, Oil Filler	1
33	14177	NBR O-Ring, Oil Filler Cap - 70D	1
34	126743	STCP R Bolt, Eye (M12) (For Lifting Pump Only)	1
38	129343	RBR Gasket, Flat	1
39	27769	ABS Stick, Dip	1
40	126531	STCP R Screw, HH (M10 x 30)	8
41	126231	STCP R Lockwasher (M10)	8
42	126574	STZP R Washer, Flat (M10)	8
48	25625	STCP Plug, Drain (1/4 x 19BSP)	1
49	23170	NBR O-Ring, Drain Plug - 70D	1
50	29438	AL Cover, Rear (See Tech Bulletin 118)	1
51	129386	NBR Gasket, Rear Cover	1
53	45303	AL Crankcase w/Guide Pins (Includes: 34, 54) (See Tech Bulletin 118)	1
54	43282	S Pin, Guide	2
55	126553	STCP R Stud (M16 x 70)	2
64	29481	CM Pin, Crosshead	3
65	† 45384	SSZZ Rod, Plunger	3
69	126588	STCP R Washer, Oil Seal	3
70	29454	NBR Seal, Oil - 80D	3
75	44752	NBR Slinger, Barrier - 85D	3
88	45677	SS Washers, Keyhole (M14)	3
90	44749	CC Plunger (M55 x 185)	3
95	89783	S Stud, Plunger Retainer (M14 x 147)	3
96	20214	PTFE Back-up-Ring, Plunger Retainer	3
97	17616	NBR O-Ring, Plunger Retainer - 80D	3
98	44751	SS Gasket, Plunger Retainer	3
99	45276	S Retainer, Plunger (M14)	3
100	855000	PVDF Retainer, Seal, 2-pc (See Tech Bulletin 105)	3
101	44762	— Wick, Long Tab (M55 x 185)	3
106	44757	NBR Seal, LPS w/SS-Spg	3
110	49457	NABC Manifold, Inlet	1
112	18175	NBR O-Ring, Spacer, Inner - 80D	3
114	44767	SS Spacer, Inlet Manifold	3
115	18175	NBR O-Ring, Spacer, Outer - 80D	3
116	126569	STCP R Lockwasher (M16)	4
117	126537	STCP R Screw, HH (M16 x 55)	4
126	48392	D Adapter, Female (See Tech Bulletin 087)	3
	45771	SS Adapter, Female	3
127	44764	STG V-Packing	6
128	45772	SS Adapter, Male	3
141	44943	SS Coil Spring, Spacer	24
142	48501	BB Spacer w/Coil Springs	3
155	18178	NBR O-Ring, Spacer - 80D	3
157	45321	SS Spacer, V-Packing	3
159	18178	NBR O-Ring, Spacer - 80D	3
160	44756	S Pin, Guide	2

ITEM	PART NUMBER	DESCRIPTION	QTY
163	18176	NBR O-Ring, Seat - 80D	6
164	† 44772	SS Seat	6
165	76304	SS Guide, Spring	6
166	76319	SS Valve, Guided, QV	6
167	76309	SS Spring	6
168	76349	PVDF Retainer, Spring	6
169	76306	SS Retainer, Bushing	6
171	44780	SS Spring, Coil, Valve Plug	6
172	18177	NBR O-Ring, Valve Plug - 80D	6
174	49461	NABC Plug, Valve [3/00]	1

ITEM	PART NUMBER	DESCRIPTION	QTY
185	49459	NABC Manifold, Discharge [3/00]	1
186	126569	STCP R Lockwasher (M16)	2
188	126744	STCP R Screw, HSH (M16 x 110)	8
194	126525	STCP R Nut, Hex (M16)	2
250	29445	AL Protector, Shaft (Included w/ Pump) (See Tech Bulletin 118)	1
255	33243	STZP Kit, Mount (Included w/Pump)	1
260	126604	STZP Rail (Included w/Pump) (Two per pump required)	2

Standard and Optional Seal Kits, Valve Kits, Optional Parts and Accessories and Service Parts listed on page 4.

EXPLODED VIEW

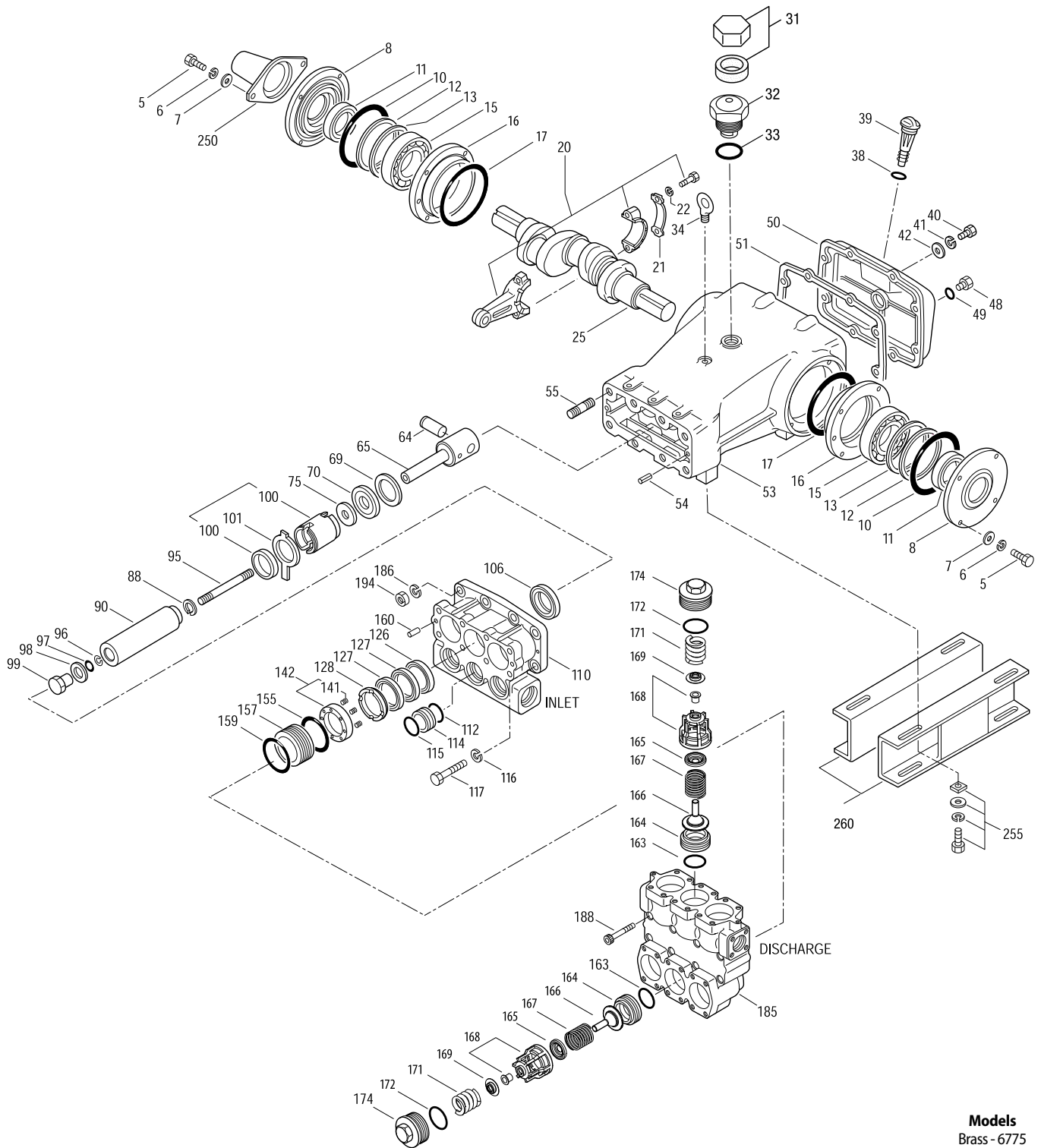

Models
 Brass - 6775
 May 2019

Italics are optional items. [] Date of latest production change. † Production parts are different than service parts.

R Components comply with RoHS Directive. * Review material codes for individual items (STG generally may be used as alternate).

See Tech Bulletins 024, 036, 043, 052, 053, 074, 083, 084, 087, 095, 105 and 118 for additional information.

MATERIAL CODES (Not Part of Part Number): ABS=ABS Plastic AL=Aluminum BB=Brass BBHS=Brass/High Strength CC=Ceramic CM=Chrome-Moly D=Acetal
 EPDM=Ethylene Propylene Diene Monomer FCM=Forged Chrome-moly FPM=Fluorocarbon NAB=Nickel Aluminum Bronze NABC=Nickel Aluminum Bronze Chrome Plated
 NBR=Medium Nitrile PE=Polyethylene (Buna-N) PTFE=Pure Polytetrafluoroethylene PVDF=Polyvinylidene RBR=Rubber Fluoride S=304SS SS=316SS
 SFTB=Special Blend PTFE Black SSZZ=316SS/Zamac STCP=Steel/Chrome Plated STG=Special Blend PTFE White STL=Steel STZP=Steel/Zinc Plated

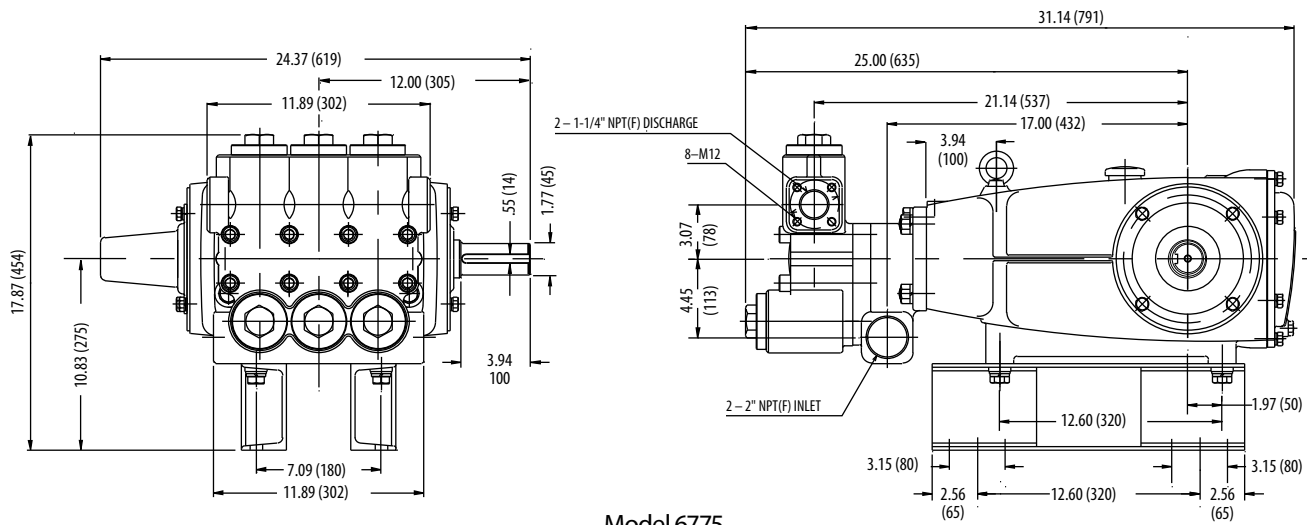

Model 6775

SEAL KITS One (1) seal kit required per pump

PUMP MODELS	NBR (STD)	FPM (.0110)	EPDM (.0220)◆
6775	34091	34093	76091

ITEM (Included in Seal Kits)				DESCRIPTION	
97	17616	11686	703369	O-Ring, Plunger Retainer	3
106	44757	45882	702228	Seal, LPS w/SS-Spg	3
112	18175	13266	702442	O-Ring, Inner Spacer	3
115	18175	13266	702442	O-Ring, Outer Spacer	3
127	44764	44764	44764	V-Packing	6
155	18178	13338	701657	O-Ring, Spacer	3
159	18178	13338	701657	O-Ring, Spacer	3

◆ Silicone Oil/Grease required

VALVE KITS Two (2) valve kits required per pump

PUMP MODELS	NBR (STD)	FPM (.0110)	EPDM (.0220)◆
6775	76140	76145	76240

ITEM (Included in Valve Kits)				DESCRIPTION	
163	18176	13278	702445	O-Ring, Seat	3
164	44772	44772	44772	Seat	3
165	76304	76304	76304	Guide, Spring	3
166	76319	76319	76319	Valve, Guided	3
168	76349	76349	76349	Retainer, Spring	3
169	76306	76306	76306	Retainer, Bushing	3
172	18177	13279	701988	O-Ring, Valve Plug	3

◆ Silicone Oil/Grease required

OPTIONAL PARTS AND ACCESSORIES

PART	DESCRIPTION	QTY
30429	Oiler (10 oz.)	3
990014	Hub, 45mm (M14 x 9 Keyway)	1
819010	Assy, Crankcase Cast Iron Conversion	1
76074	Kit, Oil Indicator (3/8" x 24") (See Individual Data Sheet)	1
34314	Kit, Oil Drain (3/8" x 48") (See Individual Data Sheet)	1
88902	Stud (M16 x 227) for removal of DM and IM	1
30696	Pliers (Reverse)	1

SERVICE PARTS

PART	DESCRIPTION	QTY
6105	Oil, Twin Pack (Two 2.5 Gallon) ISO-68 Hydraulic	1
43048	Key (M14 x 9 x 90)	1
6124	Gasket, Liquid (3 oz.)	1
996760	Head, Complete w/NBR Seals and O-Rings	1

▲ CAUTIONS AND WARNINGS

All High Pressure Systems require a primary pressure regulating device (i.e. regulator, unloader) and a secondary pressure relief device (i.e. pop-off valve, relief valve). Failure to install such relief devices could result in personal injury or damage to pump or property. Cat Pumps does not assume any liability or responsibility for the operation of a customer's high pressure system.

Read all CAUTIONS and WARNINGS before commencing service or operation of any high pressure system. The CAUTIONS and WARNINGS are included in each service manual and with each Accessory Data sheet. CAUTIONS and WARNINGS can also be viewed online at www.catpumps.com/cautions-warnings or can be requested directly from Cat Pumps.

WARRANTY

View the Limited Warranty on-line at www.catpumps.com/warranty.