

3. Performance range

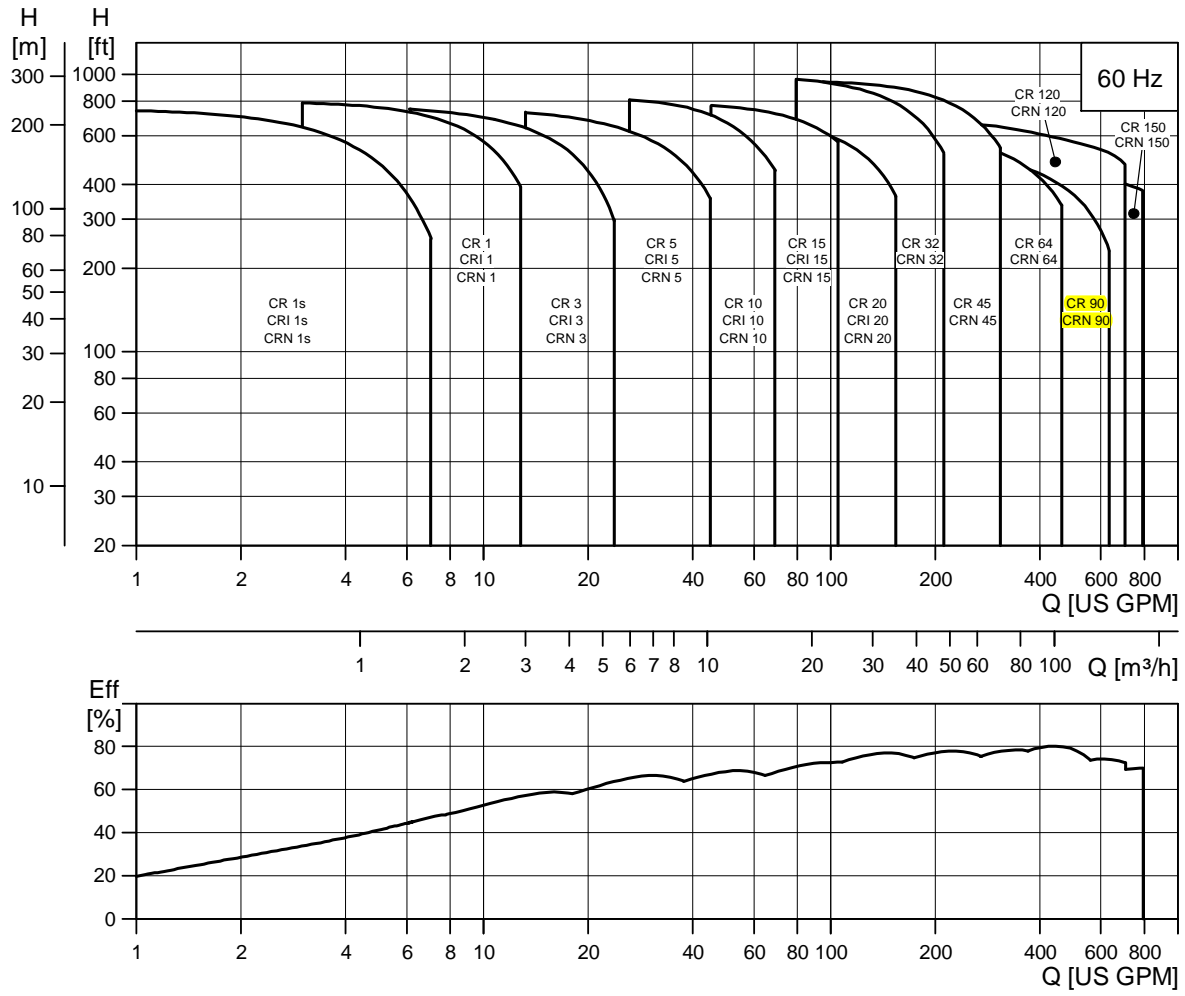

TM02 5518 0209

Range	CR 32	CR 45	CR 64	CR 90	CR 120	CR 150
Nominal flow rate [US gpm]	140	220	340	440	610	750
Temperature range [°F]	-22 to +250 ¹⁾				-22 to +250 ¹⁾ & 2)	
Temperature range [°F] - on request	-40 to +356				-	-
Max. working pressure [psi] ★	435	435	435	435	435	435
Max. working pressure [psi] - on request	580	580	580	580	-	-
Max. pump efficiency [%]	76	78	79	80	75	73
CR pumps						
CR: Flow range [US gpm]	14-210	22-310	34-450	44-630	61-700	75-790
CR: Max. pump pressure (H [ft])	995	940	565	595	685	570
CR: Motor power [Hp]	5-50	7.5-60	10-60	15-60	20-100	25-100
Version						
CR: Cast iron and stainless steel AISI 304	•	•	•	•	•	•
CRI: Stainless steel AISI 304	-	-	-	-	-	-
CRN: Stainless steel AISI 316	•	•	•	•	•	•
CRT, CRTE: Titanium	-	-	-	-	-	-
CR pipe connection						
Oval flange (NPT)	-	-	-	-	-	-
Oval flange (NPT) - on request	-	-	-	-	-	-
ANSI flange size	2.5"	3"	4"	4"	5" ³⁾	5" ³⁾
ANSI flange size - on request	3"	4"	5" ³⁾	5" ³⁾	6"	6"
ANSI flange class	125/ 250 lb.	125/ 250 lb.	125/ 250 lb.	125/ 250 lb.	125/ 250 lb.	125/ 250 lb.
CRI pipe connection						
Oval flange (NPT)	-	-	-	-	-	-
Oval flange (NPT) - on request	-	-	-	-	-	-
ANSI flange size	-	-	-	-	-	-
ANSI flange class	-	-	-	-	-	-
Clamp coupling (NPT) - on request	-	-	-	-	-	-
Union (NPT ext. Thread) - on request	-	-	-	-	-	-
CRN pipe connection						
PJE (Victaulic)	-	-	-	-	-	-
PJE (Victaulic) - on request	3"	4"	4"	4"	4"	4"
ANSI flange size	2.5"	3"	4"	4"	5"	5"
ANSI flange size - on request	3"	-	-	5"	6"	6"
ANSI flange class	150/ 300 lb.	150/ 300 lb.	150/ 300 lb.	150/ 300 lb.	150/ 300 lb.	150/ 300 lb.
Clamp coupling (NPT) - on request	-	-	-	-	-	-
Union (NPT ext. Thread) - on request	-	-	-	-	-	-
CRT pipe connection						
PJE coupling (Vitaalic)	-	-	-	-	-	-
ANSI flange size - on request	-	-	-	-	-	-

• Available.

★ See section 7. *Operating conditions* on page 13 for specific working pressures.

¹⁾ CRN 32 to CRN 90 with HQQE shaft seal: -40 °F to +250 °F.

²⁾ CR, CRN 120 and 150 with 75 or 100 Hp motors with HBQE shaft seal: 0 °F to +250 °F.

³⁾ CR 5" flange is not manufactured to ANSI specification. Gasket contact surface is approximately 0.25". CR 6" ANSI flange adapter is manufactured to ANSI B16.5 specification.

CR 32, 45, 64 and 90



TM01 2150 1298

Sectional drawing

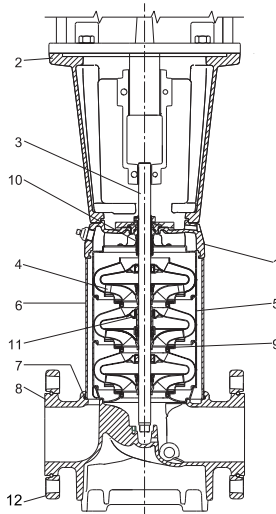

TM06 0691 0714

Materials: CR

Pos.	Designation	Materials	AISI/ASTM
1	Pump head	Cast iron EN-GJS-500-7	ASTM 80-55-06
2	Motor stool	Cast iron EN-GJL-200	ASTM 25B
3	Shaft	Stainless steel	AISI 431
4	Impeller	Stainless steel	AISI 304
5	Chamber	Stainless steel	AISI 304
6	Sleeve	Stainless steel	AISI 304
7	O-ring for sleeve	EPDM or FKM	
8	Base	Cast iron EN-GJS-500-7	ASTM 80-55-06
9	Neck ring	Carbon-graphite-filled PTFE	
10	Shaft seal		
11	Bearing ring	SiC/SiC	
12	Flange ring	Ductile iron	A 65-45-12
	Rubber parts	EPDM or FKM	

CRN 32, 45, 64 and 90



TM02 7399 3403

Sectional drawing

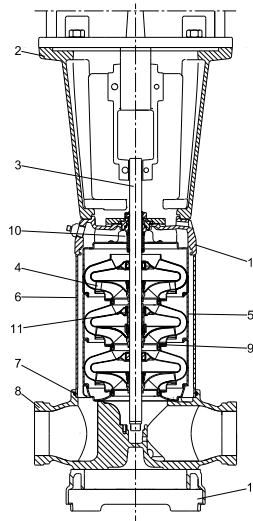

TM01 1837 3713

Materials: CRN

Pos.	Designation	Materials	AISI/ASTM
1	Pump head	Stainless steel	CF 8M equal to AISI 316
2	Motor stool	Cast iron EN-GJL-200 ¹⁾	ASTM 25B
3	Shaft	Stainless steel	
4	Impeller	Stainless steel	AISI 316
5	Chamber	Stainless steel	AISI 316
6	Sleeve	Stainless steel	AISI 316
7	O-ring for sleeve	EPDM or FKM	
8	Base	Stainless steel	CF 8M equal to AISI 316
9	Neck ring	Carbon-graphite-filled PTFE	
10	Shaft seal		
11	Bearing ring	SiC/SiC	
12	Base plate	Cast iron EN-GJS-500-7 ¹⁾	ASTM 88-55-06
	Flange ring	Ductile iron ¹⁾	A 65-45-12
	Rubber parts	EPDM or FKM	

¹⁾ Stainless steel available on request.

Pumped liquid	Note	Liquid concentration, liquid temperature	CR		CRN	
			1s, 1, 3, 5, 10, 15, 20	32, 45, 64, 90, 120, 150	1s, 1, 3, 5, 10, 15, 20	32, 45, 64, 90, 120, 150
Acetic acid CH ₃ COOH		5 %, 68 °F			HQQE	HQQE/HBQE
Acetone CH ₃ COCH ₃	1, F	100 %, 68 °F			HBQE	HQQE/HBQE
Alkaline degreasing agent	D, F		HQQE	HQQE/HBQE		
Ammonium bicarbonate NH ₄ HCO ₃	E	20 %, 86 °F			HQQE	HQQE/HBQE
Ammonium hydroxide NH ₄ OH		20 %, 104 °F	HQQE	HQQE/HBQE		
Aviation fuel	1, 3, 4, F	100 %, 68 °F	HQB	HQQV/HBQV		
Benzoic acid C ₆ H ₅ COOH	H	0,5 %, 68 °F			HQQV	HQQV/HBQV
Boiler water		< 248 °F	HQQE	HQQE/HBQE		
	F	248 °F - 356 °F	-	-		
Calcareous water		< 194 °F	HQQE	HQQE		
Calcium acetate (as coolant with inhibitor) Ca(CH ₃ COO) ₂	D, E	30 %, 122 °F	HQQE	HQQE		
Calcium hydroxide Ca(OH) ₂	E	Saturated solution, 122 °F	HQQE	HQQE		
Chloride-containing water	F	< 86 °F, max. 500 ppm			HQQE	HQQE
Chromic acid H ₂ CrO ₄	H	1 %, 68 °F			HQQV	HQQV/HBQV
Citric acid HOC(CH ₂ CO ₂ H) ₂ COOH	H	5 %, 104 °F			HQQE	HQQE/HBQE
Completely desalinated water (demineralized water)		< 248 °F			HQQE	HQQE/HBQE
Condensate		< 194 °F	HQQE	HQQE/HBQE		
Copper sulfate CuSO ₄	E	10 %, 122 °F			HQQE	HQQE
Corn oil	D, E, 3	100 %, 176 °F	HQQV	HQQV/HBQV		
Diesel oil	2, 3, 4, F	100 %, 68 °F	HQB	HQQV/HBQV		
Domestic hot water (potable water)		< 248 °F	HQQE	HQQE/HBQE		
Ethanol (ethyl alcohol) C ₂ H ₅ OH	1, F	100 %, 68 °F	HQQE	HQQE/HBQE		
Ethylene glycol HOCH ₂ CH ₂ OH	D, E	50 %, 122 °F	HQQE	HQQE		
Formic acid HCOOH		5 %, 68 °F			HQQE	HQQE/HBQE
Glycerine (glycerol) OHCH ₂ CH(OH)CH ₂ OH	D, E	50 %, 122 °F	HQQE	HQQE/HBQE		
Hydraulic oil (mineral)	E, 2, 3	100 %, 212 °F	HQQV	HQQV/HBQE		
Hydraulic oil (synthetic)	E, 2, 3	100 %, 212 °F	HQQV	HQQV/HBQE		
Isopropyl alcohol CH ₃ CHOHCH ₃	1, F	100 %, 68 °F	HQB	HQQV/HBQV		
Lactic acid CH ₃ CH(OH)COOH	E, H	10 %, 68 °F			HQQE	HQQE/HBQE
Linoleic acid C ₁₇ H ₃₁ COOH	E, 3	100 %, 68 °F	HQQV	HQQV/HBQV		
Methanol (methyl alcohol) CH ₃ OH	1, F	100 %, 68 °F	HQQE	HQQE/HBQE		
Motor oil	E, 2, 3	100 %, 176 °F	HQQV	HQQV/HBQV		
Naphthalene C ₁₀ H ₈	E, H	100 %, 176 °F	HQQV	HQQV/HBQV		
Nitric acid HNO ₃	F	1 %, 68 °F			HQQE	HQQE/HBQE
Oil-containing water		< 212 °F	HQQV	HQQV/HBQV		
Olive oil	D, E, 3	100 %, 176 °F	HQQV	HQQV/HBQV		
Oxalic acid (COOH) ₂	H	1 %, 68 °F			HQQE	HQQE/HBQE
Ozone-containing water (O ₃)		1 PPM, < 105 °F			HQQE	HQQE/HBQE
Peanut oil	D, E, 3	100 %, 194 °F	HQQV	HQQV/HBQV		
Petrol/gasoline	1, 3, 4, F	100 %, 68 °F	HQB	HQQV/HBQV		
Phosphoric acid H ₃ PO ₄	E	20 %, 68 °F			HQQV	HQQV/HBQV
Propanol C ₃ H ₇ OH	1, F	100 %, 68 °F	HQQV	HQQV/HBQV		
Propylene glycol CH ₃ CH(OH)CH ₂ OH	D, E	50 %, 194 °F	HQQE	HQQE		
Potassium carbonate K ₂ CO ₃	E	20 %, 122 °F	HQQE	HQQE		
Potassium formate (as coolant with inhibitor) KOOCH	D, E	30 %, 122 °F	HQQE	HQQE		
Potassium hydroxide KOH	E	20 %, 122 °F			HQQE	HQQE
Potassium permanganate Kmno ₄		5 %, 68 °F			HQQE	HQQE/HBQE
Rape seed oil	D, E, 3	100 %, 176 °F	HQQV	HQQV/HBQV		
Salicylic acid C ₆ H ₄ (OH)COOH	H	0,1 %, 68 °F			HQQE	HQQE/HBQE
Silicone oil	E, 3	100 %	HQQV	HQQV/HBQV		
Sodium bicarbonate NaHCO ₃	E	10 %, 140 °F			HQQE	HQQE/HBQE
Sodium chloride (as coolant) NaCl	D, E	30 %, < 41 °F, pH > 8	HQQE	HQQE		
Sodium hydroxide NaOH	E	20 %, 122 °F			HQQE	HQQE
Sodium hypochlorite NaOCl	F	0,1 %, 68 °F			HQQE	HQQE
Sodium nitrate NaNO ₃	E	10 %, 140 °F			HQQE	HQQE/HBQE

Pumped liquid	Note	Liquid concentration, liquid temperature	CR		CRN	
			1s, 1, 3, 5, 10, 15, 20	32, 45, 64, 90, 120, 150	1s, 1, 3, 5, 10, 15, 20	32, 45, 64, 90, 120, 150
Sodium phosphate Na ₃ PO ₄	E, H	10 %, 140 °F			HQQE	HQQE
Sodium sulfate Na ₂ SO ₄	E, H	10 %, 140 °F			HQQE	HQQE/HBQE
Softened water		< 248 °F			HQQE	HQQE/HBQE
Soybean oil	D, E, 3	100 %, 176 °F	HQQV	HQQV/HBQV		
Sulfuric acid H ₂ SO ₄	F	1 %, 68 °F			HQQV	HQQV/HQQV
Sulfurous acid H ₂ SO ₃		1 %, 68 °F			HQQE	HQQE/HBQE
Swimming pool water (low chloride)		Max 5 ppm free chlorine (Cl ₂)	HQQE	HQQE/HBQE		

Operating range of the shaft seal

The operating range of the shaft seal depends on operating pressure, pump type, type of shaft seal and liquid temperature. The following curves apply to clean water and water with anti-freeze liquids. For selecting the right shaft seal, see [Pumped liquids](#) on page 13.

CR 1s - CR 20

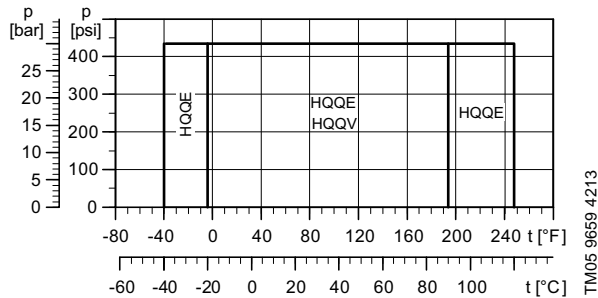

Fig. 5 Operating range of standard shaft seals for CR 1s - CR 20

CR 32 - CR 150 (3.0-60 Hp)

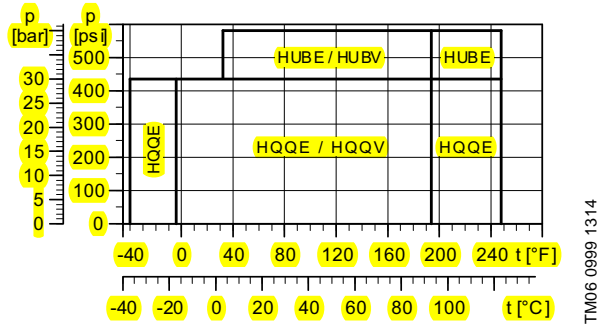

Fig. 6 Operating range of standard shaft seals for CR 32 - CR 150 (3.0-60 Hp)

CR 120 - CR 150 (75-100 Hp)

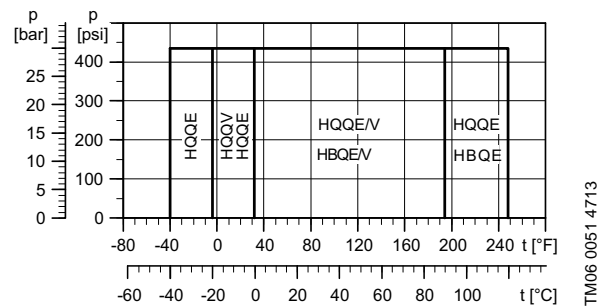

Fig. 7 Operating range of standard shaft seals for CR 120 - CR 150 (75-100 Hp)

Shaft seal	Description	Max. temp. range [°F]
HQQE	O-ring (cartridge) (balanced seal), SiC/SiC, EPDM	-40 °F to +248 °F
HBQE	O-ring (cartridge) (balanced seal), Carbon/SiC, EPDM	+32 °F to +248 °F
HBQV	O-ring (cartridge) (balanced seal), Carbon/SiC, FKM	+32 °F to +194 °F
HQQV	O-ring (cartridge) (balanced seal), SiC/SiC, FKM	-4 °F to +194 °F
HUBE	O-ring (cartridge) (balanced seal), TC/carbon, EPDM	+32 °F to +248 °F
HUBV	O-ring (cartridge) (balanced seal), TC/carbon, FKM	+32 °F to +194 °F

Note: TC= tungsten carbide

See section [Lists of variants - on request](#) on page 77, in case of extreme temperatures:

- low temperatures down to -40 °F or
- high temperatures up to +356 °F.

Maximum inlet pressure

The following table shows the maximum permissible inlet pressure. However, the current inlet pressure + the pressure against a closed valve **must** always be lower than the maximum permissible operating pressure.

If the maximum permissible operating pressure is exceeded, the bearing in the motor may be damaged and the life of the shaft seal reduced.

Pump type	Stages		Max. [psi (bar)]
	60 Hz	50 Hz	
CR, CRI, CRN 1s	2-27	2-36	145 (10)
CR, CRI, CRN 1	2-25 27	2-36	145 (10) 217 (15)
CR, CRI, CRN 3	2-17 19-25	2-29 31-36	145 (10) 217 (15)
CR, CRI, CRN 5	2-9 10-24	3-16 18-36	145 (10) 217 (15)
CR, CRI, CRN 10	1-5 6-17	1-6 7-22	116 (8) 145 (10)
CR, CRI, CRN 15	1-2 3-12	1-3 4-17	116 (8) 145 (10)
CR, CRI, CRN 20	1 2-10	1-3 4-17	116 (8) 145 (10)
CR, CRN 32	1-1 - 2 3-2 - 6 7-2 - 11-2	1-1 - 4 5-2 - 10 11-14	58 (4) 145 (10) 217 (15)
CR, CRN 45	1-1 - 1 2-2 - 3 4-2 - 8-1	1-1 - 2 3-2 - 5 6-2 - 13-2	58 (4) 145 (10) 217 (15)
CR, CRN 64	1-1 1 - 2-1 2 - 5-2	1-1 - 2-2 2-1 - 4-2 4-1 - 8-1	58 (4) 145 (10) 217 (15)
CR, CRN 90	1-1 - 1 2-2 - 4-1	1-1 - 1 2-2 - 3-2 3-6	58 (4) 145 (10) 217 (15)
CR, CRN 120	1-1 - 1 2-2 - 3 4-1 - 5-1	1 - 2-1 2 - 5-1 6-1 - 7	145 (10) 217 (15) 290 (20)
CR, CRN 150	1-1 1-2 3-2 - 4-1	1-1 - 1 2-1 - 4-1 5-2 - 6	145 (10) 217 (15) 290 (20)

Example of operating and inlet pressures

The values for operating and inlet pressures shown in the tables must not be considered individually but must always be compared, see the following examples:

Example 1:

The following pump type has been selected: CR 3-10 A-A-A

Max. operating pressure: **232 psi**

Max. inlet pressure: **145 psi**

Discharge pressure against a closed valve: **139.2 psi**, see page 43.

This pump is not allowed to start at an inlet pressure of 145 psi, but at an inlet pressure of $232.0 - 139.2 = 92.8$ psi.

Example 2:

The following pump has been selected: CR 10-2 A-GJ-A

Max. operating pressure: **232 psi**

Max. inlet pressure: **116 psi**

Discharge pressure against a closed valve: **42 psi (97 ft)**, see page 49.

This pump is allowed to start at an inlet pressure of 116 psi, as the discharge pressure is only 42 psi, which results in an operating pressure of $116 + 42 = 158$ psi. On the contrary, the max. operating pressure of this pump is limited to 158 psi, as a higher operating pressure will require an inlet pressure of more than 116 psi.

In case the inlet or operating pressure exceeds the pressure permitted, see section [Lists of variants - on request](#) on page 77.

CR, CRN 90

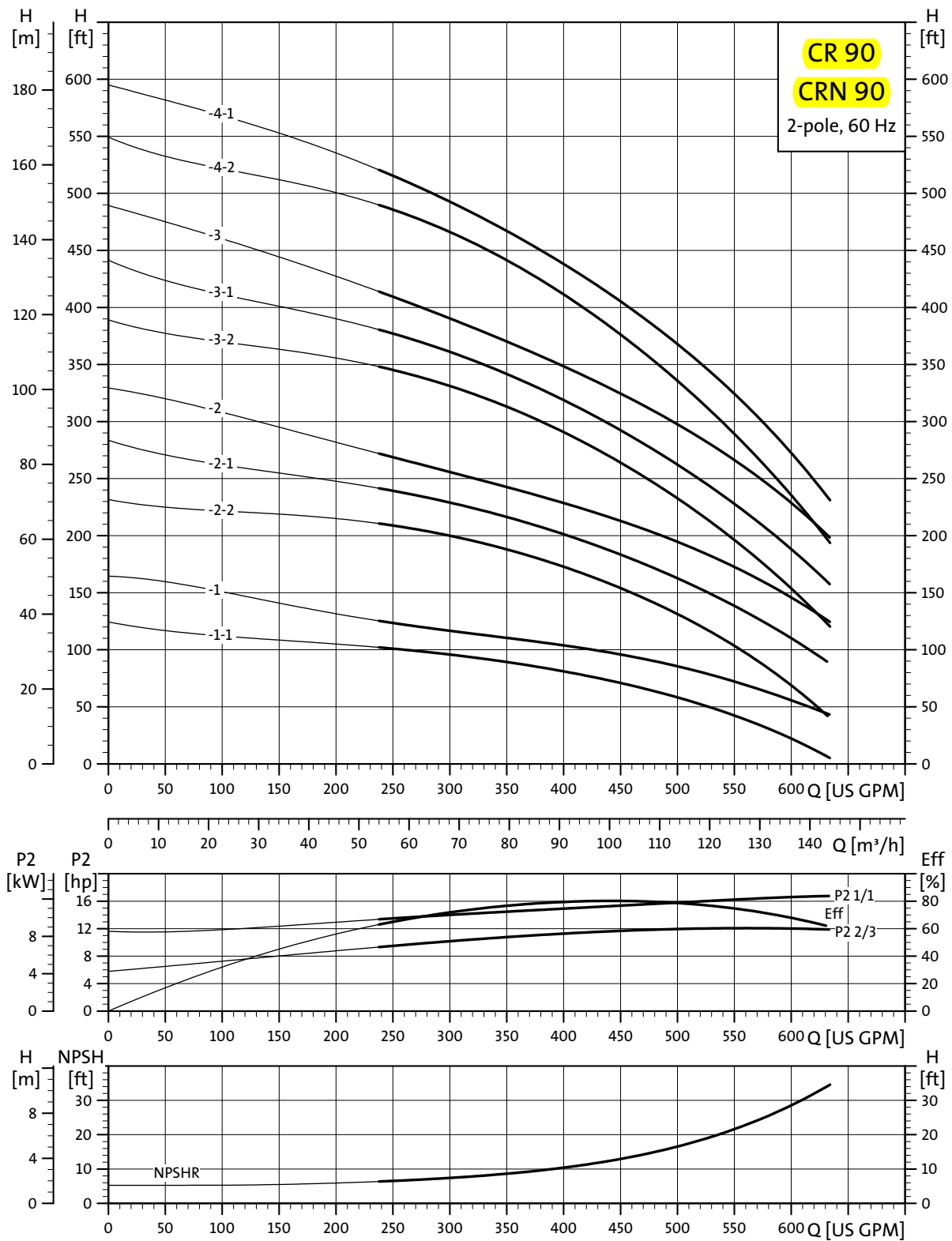

TM02 0042 1303

CR 90

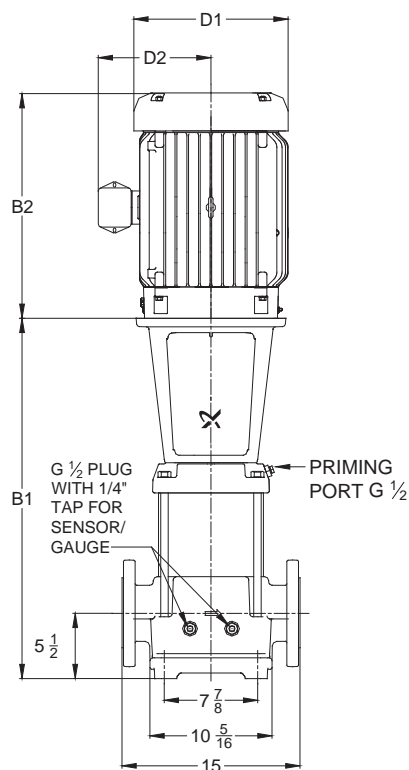

4-5 STAGES

4" ANSI
250 LB R.F.

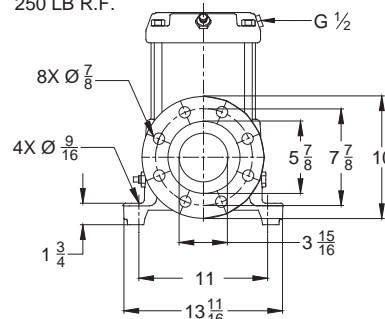

1-3 STAGES

4" ANSI
125 LB R.F.

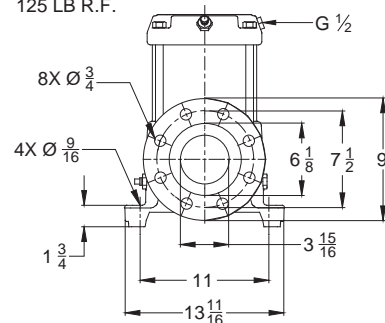

TM02 7702 3804

Pump type	P2 [Hp]	Ph.	ANSI dimensions [inch (mm)]									Ship. wt. ¹⁾ [lbs (kg)]
			B1	TEFC			ODP					
				D1	D2	B1+B2	D1	D2	B1+B2			
CR 90-1-1	15	3	26.81 (681)	12.36 (314)	8.00 (204)	45.35 (1152)	10.62 (270)	7.33 (187)	43.12 (1096)	358 (163)		
CR 90-1	20	3	26.81 (681)	12.36 (314)	8.00 (204)	45.35 (1152)	11.50 (293)	8.92 (227)	46.50 (1182)	363 (165)		
CR 90-2-2	25	3	30.43 (773)	12.36 (314)	8.00 (204)	52.82 (1342)	11.50 (293)	8.94 (228)	51.24 (1302)	367 (167)		
CR 90-2-1	30	3	30.43 (773)	12.36 (314)	8.00 (204)	52.82 (1342)	11.50 (293)	8.94 (228)	52.24 (1327)	432 (196)		
CR 90-2	40	3	30.43 (773)	15.32 (390)	13.11 (333)	53.62 (1362)	13.25 (337)	12.21 (311)	53.68 (1364)	625 (284)		
CR 90-3-2	40	3	34.06 (866)	15.32 (390)	13.11 (333)	57.25 (1455)	13.25 (337)	12.21 (311)	57.31 (1456)	636 (289)		
CR 90-3-1	50	3	34.06 (866)	16.88 (429)	14.12 (359)	61.87 (1572)	13.25 (337)	12.21 (311)	56.81 (1443)	667 (303)		
CR 90-3	50	3	34.06 (866)	16.88 (429)	14.12 (359)	61.87 (1572)	13.25 (337)	12.21 (311)	56.81 (1443)	667 (303)		
CR 90-4-2	60	3	37.68 (958)	19.00 (483)	14.90 (379)	68.47 (1740)	15.12 (385)	13.19 (336)	63.81 (1621)	869 (395)		
CR 90-4-1	60	3	37.68 (958)	19.00 (483)	14.90 (379)	68.47 (1740)	15.12 (385)	13.19 (336)	63.81 (1621)	869 (395)		

¹⁾ Weights are based on pump with TEFC motor (see price list for individual weights).
All dimensions in inches unless otherwise noted.

CRN 90

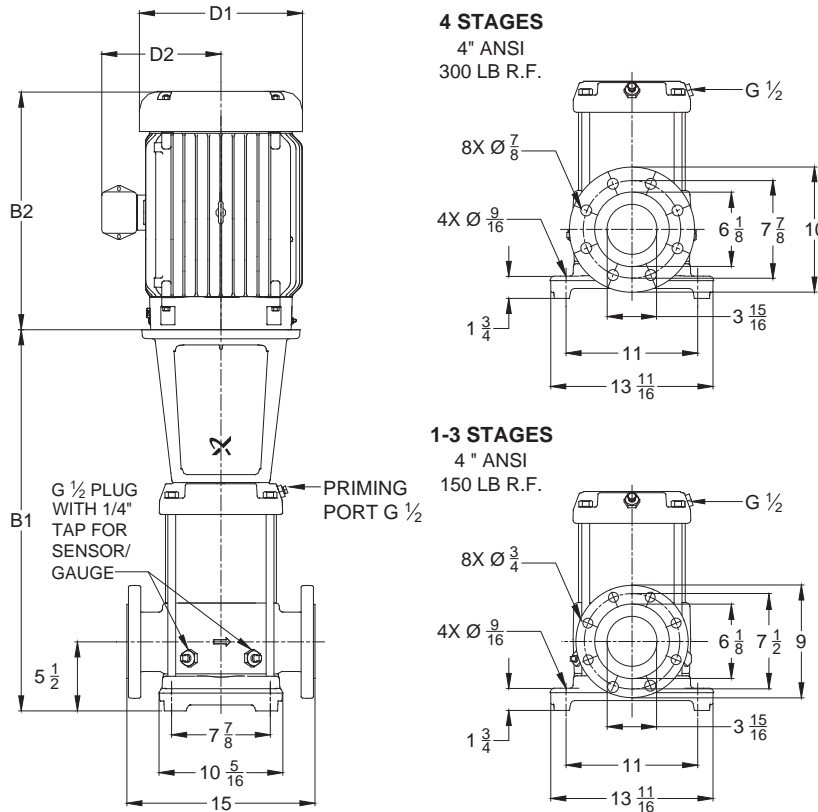

TM02 7706 3804

Pump type	P2 [Hp]	Ph.	ANSI dimensions [inch (mm)]									Ship. wt. ¹⁾ [lbs (kg)]
			B1	TEFC			ODP					
				D1	D2	B1+B2	D1	D2	B1+B2			
CRN 90-1-1	15	3	26.81 (681)	12.36 (314)	8.00 (204)	45.35 (1152)	10.62 (270)	7.33 (187)	43.12 (1096)	364 (166)		
CRN 90-1	20	3	26.81 (681)	12.36 (314)	8.00 (204)	45.35 (1152)	11.50 (293)	8.92 (227)	46.50 (1182)	369 (168)		
CRN 90-2-2	25	3	30.43 (773)	12.36 (314)	8.00 (204)	52.82 (1342)	11.50 (293)	8.94 (228)	51.24 (1302)	372 (169)		
CRN 90-2-1	30	3	30.43 (773)	12.36 (314)	8.00 (204)	52.82 (1342)	11.50 (293)	8.94 (228)	52.24 (1327)	450 (205)		
CRN 90-2	40	3	30.43 (773)	15.32 (390)	13.11 (333)	53.62 (1362)	13.25 (337)	12.21 (311)	53.68 (1364)	631 (287)		
CRN 90-3-2	40	3	34.06 (866)	15.32 (390)	13.11 (333)	57.25 (1455)	13.25 (337)	12.21 (311)	57.31 (1456)	642 (292)		
CRN 90-3-1	50	3	34.06 (866)	16.88 (429)	14.12 (359)	61.87 (1572)	13.25 (337)	12.21 (311)	56.81 (1443)	668 (304)		
CRN 90-3	50	3	34.06 (866)	16.88 (429)	14.12 (359)	61.87 (1572)	13.25 (337)	12.21 (311)	56.81 (1443)	672 (305)		
CRN 90-4-2	60	3	37.68 (958)	19.00 (483)	14.90 (379)	68.47 (1740)	15.12 (385)	13.19 (336)	63.81 (1621)	876 (398)		
CRN 90-4-1	60	3	37.68 (958)	19.00 (483)	14.90 (379)	68.47 (1740)	15.12 (385)	13.19 (336)	63.81 (1621)	876 (398)		

¹⁾ Weights are based on pump with TEFC motor (see price list for individual weights). All dimensions in inches unless otherwise noted.

11. Motor data

Standard motors in the CR range

Motors used in the CR pump range are:

- Grundfos ML motors
- Grundfos specified **Baldor®** motors.

The information in the tables below applies to following motors type and size:

Type	Phase	Motor range [Hp]	Cooling method
ML	3	1/3 - 30	TEFC
	1	1/3 - 10	TEFC
Baldor	3	40-100	TEFC
	3	15-125	ODP

Grundfos CR pumps are supplied with heavy-duty 2-pole, NEMA energy efficient C-frame motors built or selected to our rigid specifications. All CR pump motors have heavy-duty bearings for maximum thrust requirements.

ODP motors

(Open Drip Proof, constant speed)

Hp	Ph	ODP frame	ODP S.F.	ODP voltage [V]	ODP motor eff. %	ODP insul. class	ODP KVA code	ODP full load current	ODP service factor current	ODP starting current
15	3	254TCZ	1.15	208-230/460	89.5	F	H	37-35 / 17.5	40 - 39.4 / 19.7	225-248/124
20	3	254TC	1.15	230/460	90.2	B	G	48/24	55 /27.5	306/153
25	3	284TSCZ	1.15	208-230/460	91	B	G	64-59 / 29.5	74-67 / 33.5	335-374/187
30	3	284TSC	1.15	230/460	91	F	H	70/35	80/40	480/240
40	3	286TSCZ	1.15	230/460	91.7	F	F	94/47	108/54	542/271
50	3	324TSCZ	1.15	230/460	92.4	F	G	116/58	134/67	706/353
60	3	324TSCZ	1.15	230/460	93	B	G	132/66	152/76	844/422
75	3	364TSCZ	1.15	230/460	93	F	G	168/84	192/96	1110/555
100	3	365TSCZ	1.15	230/460	93	F	G	226/113	260/130	1380/690
125	3	405TSCZ	1.15	460	93.6	B	G	140	171	897

Baldor motor



TIM02 7696 3803

It is not recommended that an off-the-shelf standard Baldor motor be used on a Grundfos pump. Ideally, the best motor choice would be the Grundfos specified motor.

Single-phase Grundfos specified motors up to 7.5 Hp have a built-in thermal overload switch.

Other motor types are available (i.e., Explosion proof, Mill and Chem duty, Premium Efficiency, etc.); consult local Grundfos company for more information.

Pumps supplied by Grundfos Canada are normally supplied with motors from other manufactures. 575 volt motors meet NEMA energy efficient standards.

Dimensions and data will vary, contact local Grundfos company for more information.

All values are subject to change without notice.