

## SELF PRIMING CENTRIFUGAL PUMPS

### Stainless Steel Centrifugal Pump

The **Webtrol Stainless Steel Self Priming Centrifugal Pump** is the professionals choice when it comes to a self priming centrifugal that has a suction lift of 25'. In many applications it is not possible to install the pump below the water line of the fluid being pumped, to provide a gravity flow into the pump. The Webtrol stainless steel, self priming centrifugal pump is designed to be installed above the water line where a suction lift would be required.

These versatile and reliable pumps offer a superior alternative to standard cast iron jet or centrifugal pumps.

To insure that you have no problems at startup and thought the operation of the pump, every complete pump is thoroughly water tested for performance, electrical draw, noise and vibration.



#### Features

---

- **Close Coupled** for smooth transmission of power.
- **304L Stainless Steel** pump case, motor bracket and impeller.
- **Centerline Discharge** provide maximum resistance to misalignment.
- **Non-Overloading Motor** rated for continuous duty throughout the entire operating range.
- **High Operating Efficiency** over a wide range of capacities.
- **Back Pullout Design** for ease of servicing the pump without disturbing the piping system.
- **Mechanical Seal** for maximum reliability and economic value.

#### Performance

---

Capacities to 19 GPM  
Heads to 180'

#### Typical Services

---

- Home drinking water systems
- Deionized Systems
- Reverse Osmosis Systems
- Distribution Systems
- Misting Systems
- Car Wash Systems
- Liquid Transfer Systems
- Circulation Systems
- Pre-Filter Charge System
- Condensation Systems
- Cooling Tower Systems

## SELF PRIMING, STAINLESS STEEL, CENTRIFUGAL PUMP SPECIFICATIONS



### SPC Models

<b>Size:</b>	Suction	All Models . . . . .1 1/4" NPT
	Discharge	All Models . . . . .1 1/4" NPT
<b>Liquid Handled:</b>	Type of liquid . . . . .	Clean Water
	Temperature of Liquid . . .	113 Degrees (F) Max.
	Working Pressure . . . . .	.85 PSI Max.
	Suction Lift . . . . .	.25 Ft. @ 68 degrees (F)
<b>Materials:</b>	Casing . . . . .	.304 Stainless Steel
	Impeller . . . . .	.304 Stainless Steel
	Shaft . . . . .	Stainless Steel
	Bracket . . . . .	Aluminum
	Mechanical Seal . . . . .	Carbon/Ceramic
<b>Motor:</b>	Type . . . . .	NEMA 56J / ODP or TEFC
	Speed . . . . .	.3450 RPM (2 pole)
	Phase / Voltage . . . . .	1 Phase 115/230V
		3 Phase 208-230/460V
	Housing . . . . .	Aluminum
	Rotation . . . . .	Clockwise when viewed from motor end

## SPC SERIES GROUP CURVES

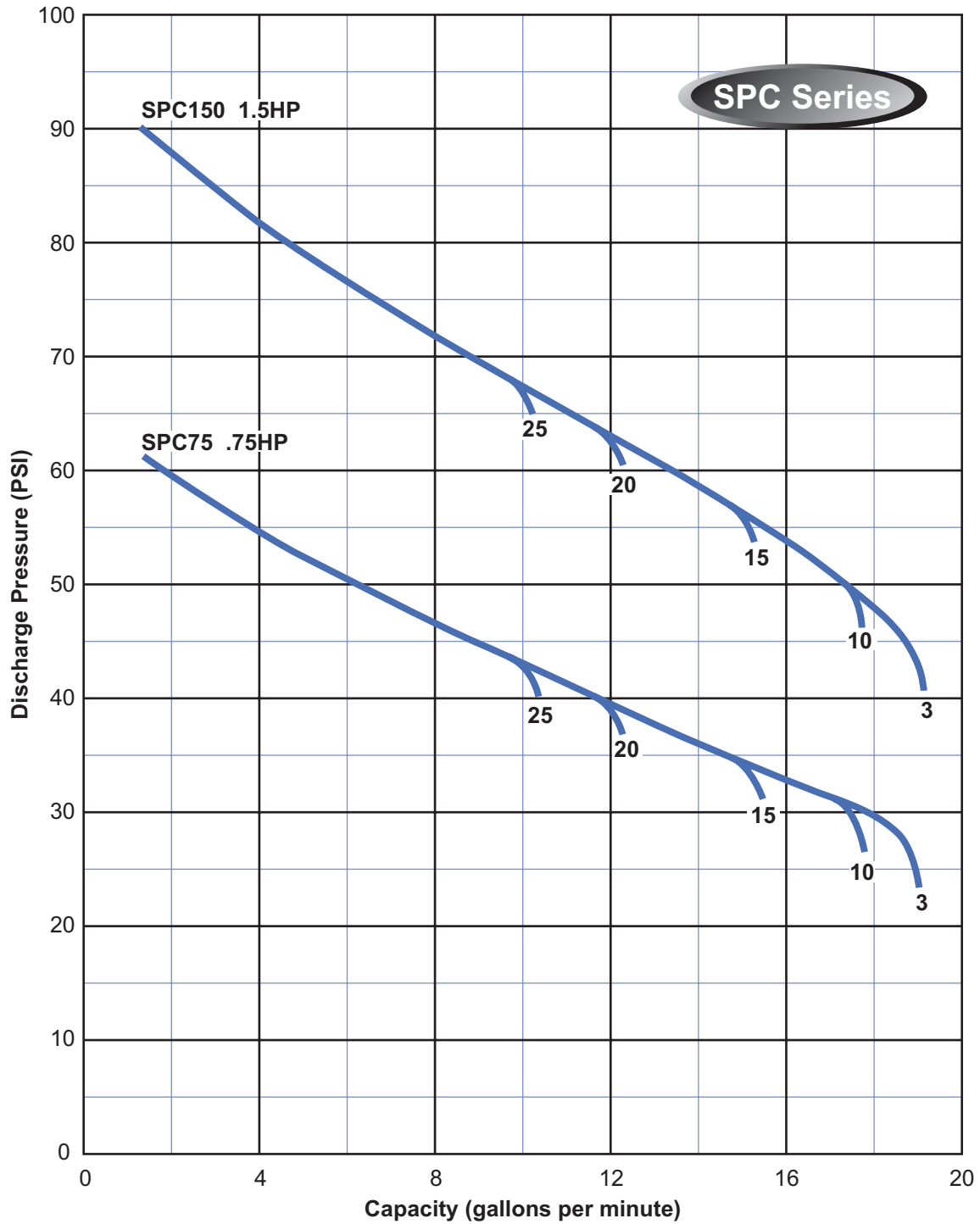

## SPC SERIES CURVES

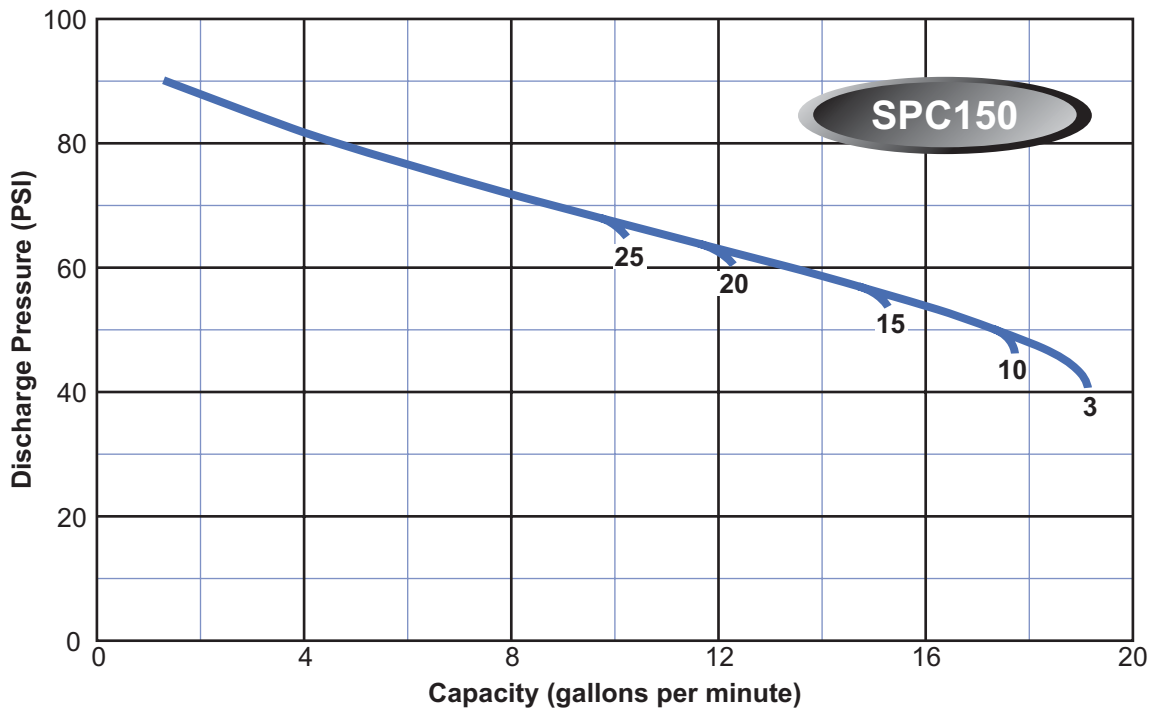
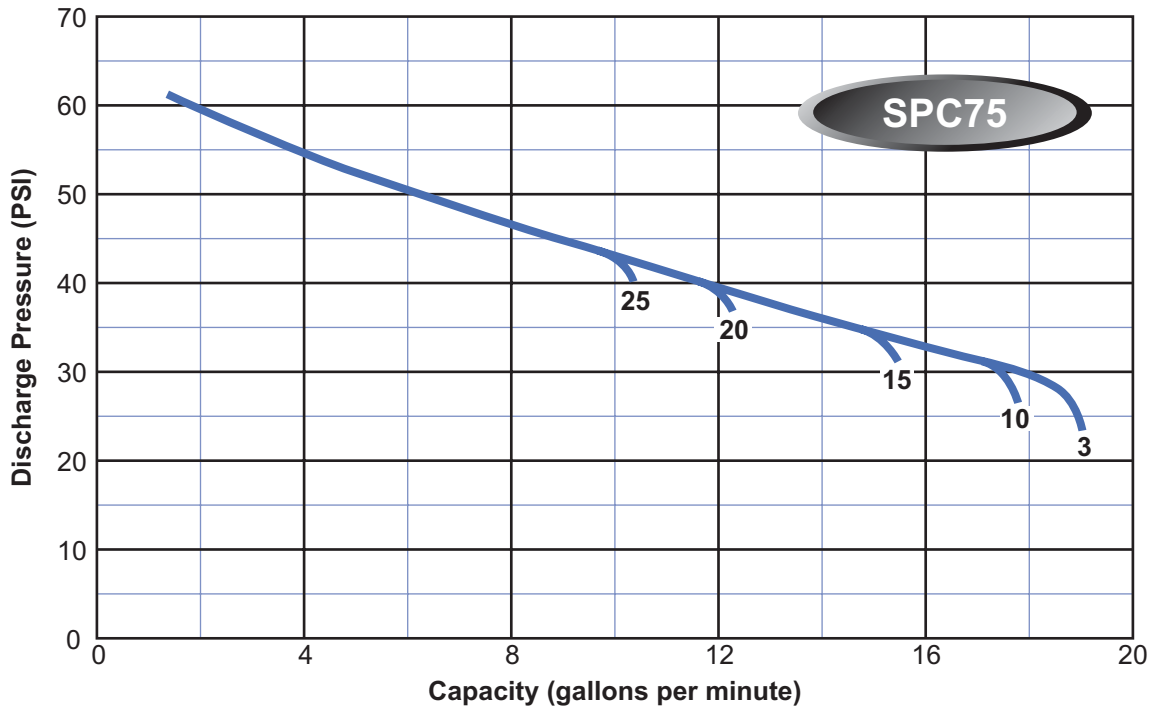

## SELF PRIMING CENTRIFUGAL PUMP Dimensions

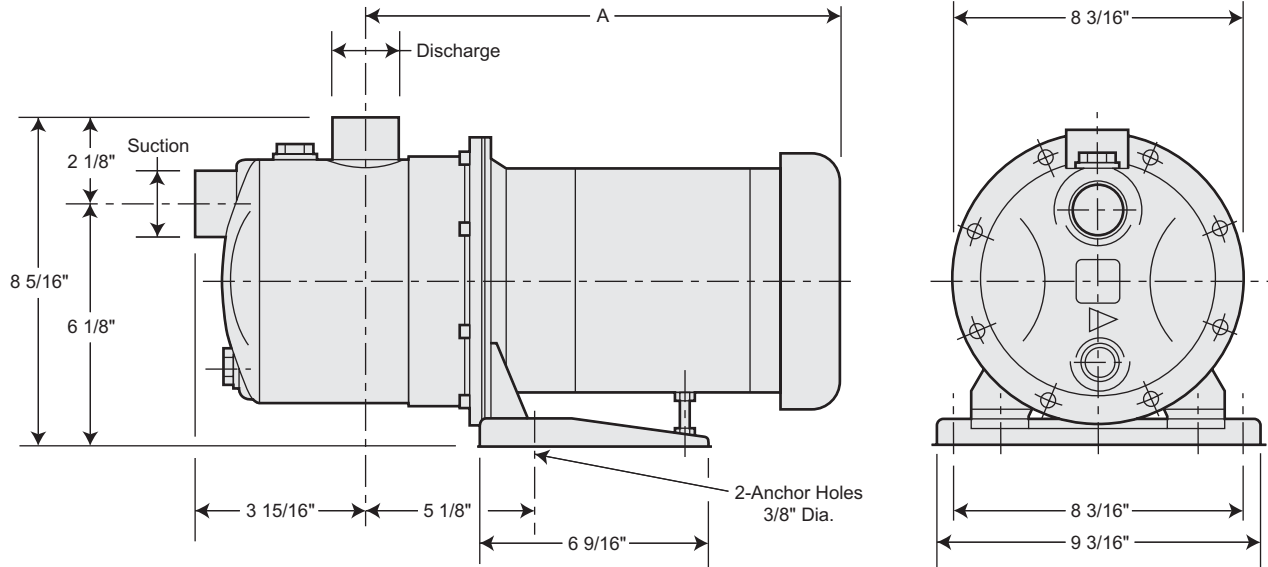

Model No.	Discharge / Suction / Imp. (inch-NPTF)	"A" Dimension	Single Phase Unit Weight (lbs.)		Three Phase Unit Weight (lbs.)	
			ODP	TEFC	ODP	TEFC
SPC75	1" x 1 1/4" x 4 1/2"	15 1/8"	37	41	39	43
SPC150	1" x 1 1/4" x 5 3/16"	15 9/16"	42	46	44	48